

Operating Temperature: 0°C~70°C  
 Operating Humidity: 20%~80% (no condensation)  
 Storage Temperature: -25°C~85°C  
 Storage Humidity: 20%~80% (no condensation)

L:  
 CBL-D302MBS-5m 5000mm±30mm  
 CBL-D302MBS-7m 7000mm±30mm  
 CBL-D302MBS-10m 10000mm±30mm

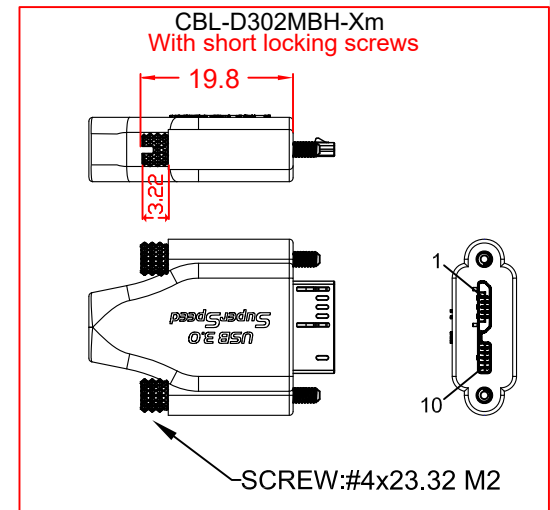
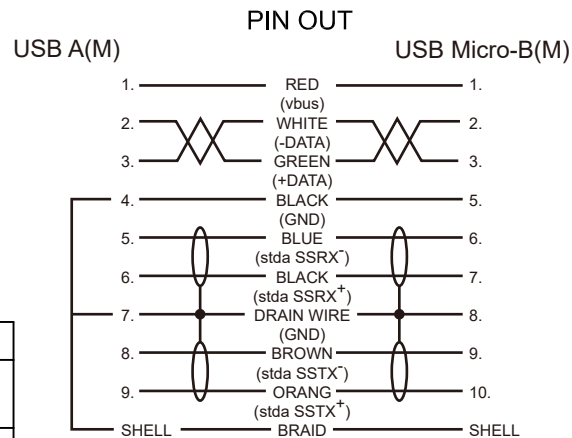

| No | MATERIALS LIST:  |
|----|--|
| 1. | CABLE:UL2725 (28AWG*1PR+D+AM)x2C+28AWG*1PR+24AWG*1C+AM+B OD:5.6mm PVC JACKET COLOR:BLACK   |
| 2. | CONNECTOR:USB 3.0 A/M, 9P, BLUE INSULATOR SOLDER TYPE, PIN 30u" NICKEL PLATED SHELL        |
| 3. | CONNECTOR:USB 3.0 MicroB/M, 10P, BLACK INSULATOR SOLDER TYPE, PIN 30u" NICKEL PLATED SHELL |
| 4. | PVC MOLDED HOUSING, BLACK COLOR  |
| 5. | SCREW:#4x33 M2   |

| Jargy part no.                | Client part no. | Approved | SCALE | UNIT |
|-------------------------------|-----------------|----------|-------|------|
| CBL-D302MBS-Xm                |                 |          |       | mm   |
| Drawing Name                  |                 | Drawn    | Date  | REV. |
| USB 3.0 A to MicroB Cable M/M |                 |          |       | 1.0  |

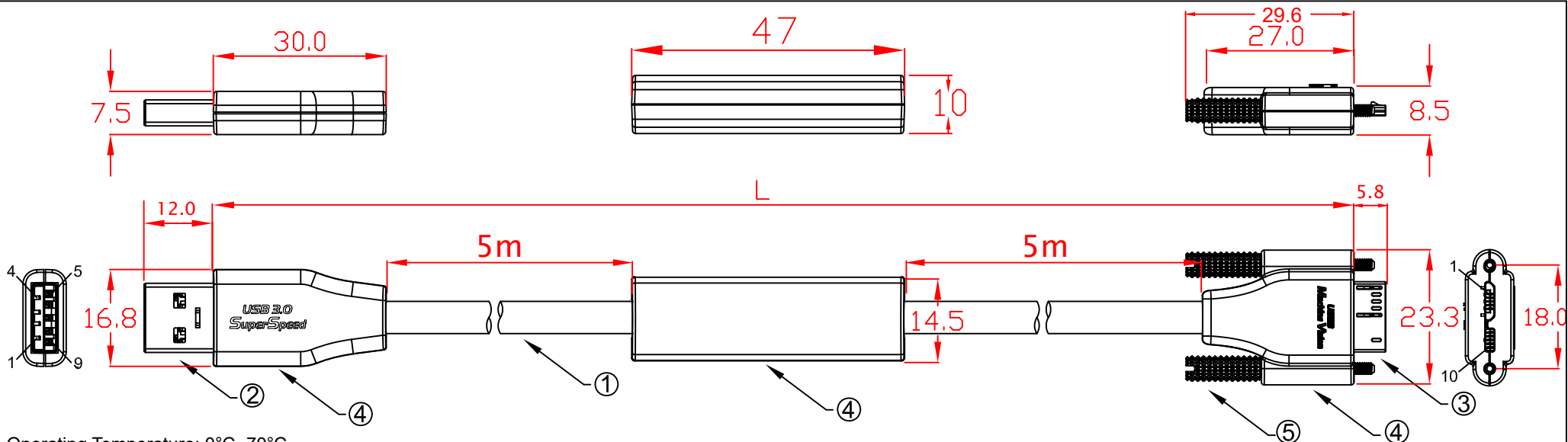

Operating Temperature: 0°C~70°C  
 Operating Humidity: 20%~80% (no condensation)  
 Storage Temperature: -25°C~85°C  
 Storage Humidity: 20%~80% (no condensation)

L:  
 CBL-D302MBS-5m 5000mm±30mm  
 CBL-D302MBS-7m 7000mm±30mm  
 CBL-D302MBS-10m 10000mm±30mm

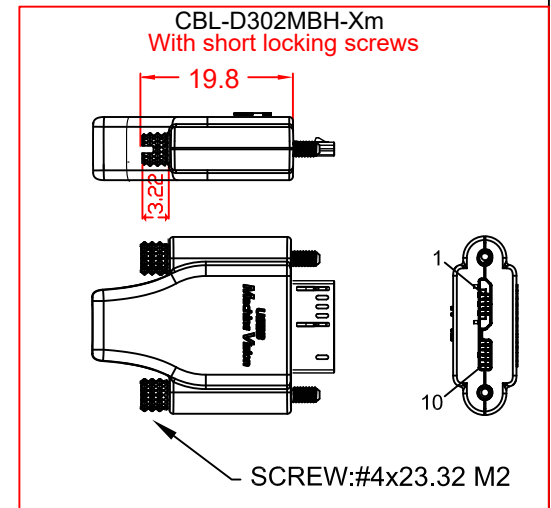
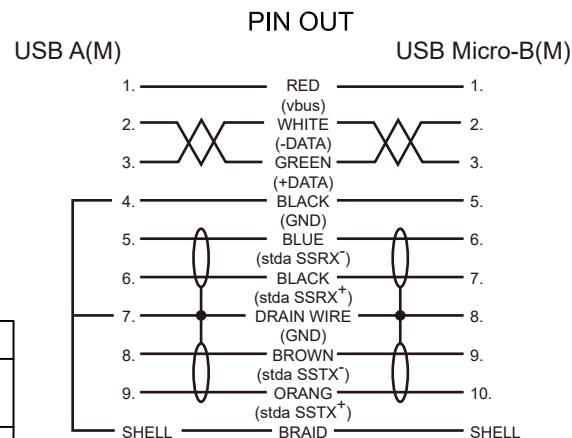

| No | MATERIALS LIST:  |
|----|--|
| 1. | CABLE:UL2725 (28AWG*1PR+D+AM)x2C+28AWG*1PR+24AWG*1C+AM+B OD:5.6mm PVC JACKET COLOR:BLACK |
| 2. | CONNECTOR:USB 3.0 A/M, 9P, BLUE INSULATOR SOLDER TYPE, NICKEL PLATED SHELL               |
| 3. | CONNECTOR:USB 3.1 TYPE-C, MALE, NICKEL PLATED SHELL                                      |
| 4. | ABS HOUSING, BLACK COLOR   |
| 5. | SCREW:#4x33 M2   |

| Jargy part no.                | Client part no. | Approved | SCALE | UNIT |
|-------------------------------|-----------------|----------|-------|------|
| CBL-D302MBS-Xm                |                 |          |       | mm   |
| Drawing Name                  |                 | Drawn    | Date  | REV. |
| USB 3.0 A to MicroB Cable M/M |                 |          |       | 1.0  |

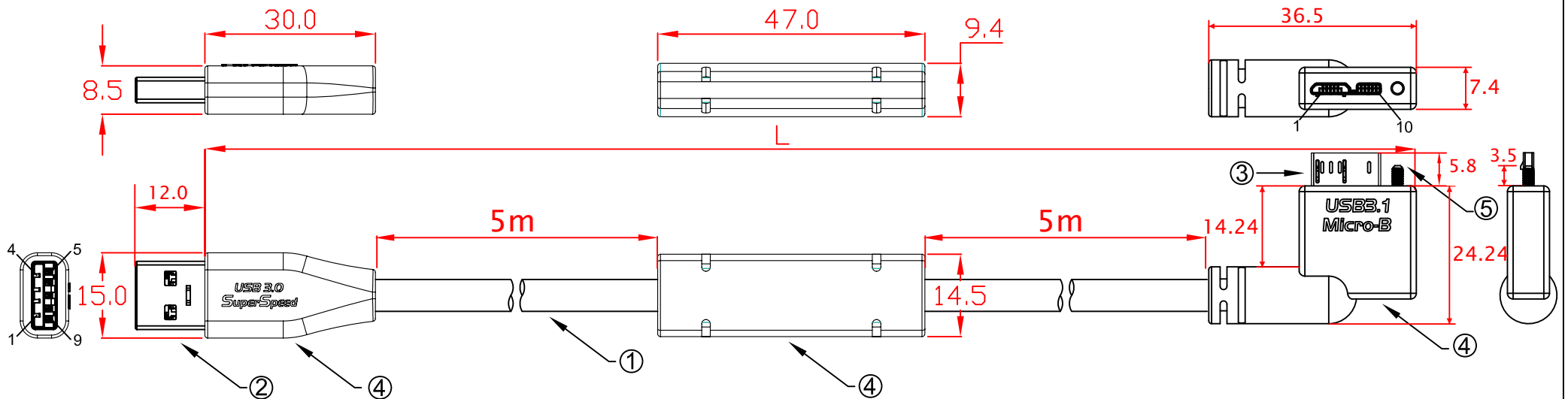

Operating Temperature: 0°C~70°C  
 Operating Humidity: 20%~80% (no condensation)  
 Storage Temperature: -25°C~85°C  
 Storage Humidity: 20%~80% (no condensation)

L:  
 CBL-D302MBHM-5mLA 5000mm±30mm  
 CBL-D302MBHM-7mLA 7000mm±30mm  
 CBL-D302MBHM-10mLA 10000mm±30mm

| No | MATERIALS LIST:  |
|----|--|
| 1. | CABLE:UL2725 (28AWG*1PR+D+AM)x2C+28AWG*1PR+24AWG*1C+AM+B OD:5.6mm PVC JACKET COLOR:BLACK |
| 2. | CONNECTOR:USB 3.0 A/M, 9P, BLUE INSULATOR SOLDER TYPE, NICKEL PLATED SHELL               |
| 3. | CONNECTOR:USB 3.0 MicroB/M, 10P, BLACK INSULATOR SOLDER TYPE, NICKEL PLATED SHELL        |
| 4. | PVC MOLDED HOUSING, BLACK COLOR  |
| 5. | SCREW:#4x23.32 M2  |
| 6. |  |

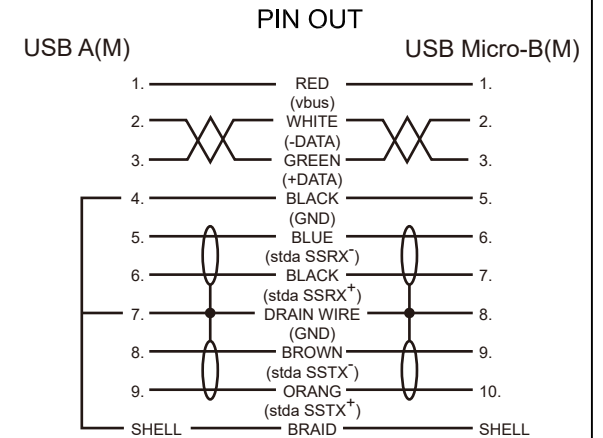

| Jargy part no.                | Client part no. | Approved | SCALE | UNIT |
|-------------------------------|-----------------|----------|-------|------|
| CBL-D302MBHM-xmLA             |                 |          |       | mm   |
| Drawing Name                  |                 | Drawn    | Date  | REV. |
| USB 3.0 A to MicroB Cable M/M |                 |          |       | 1.0  |

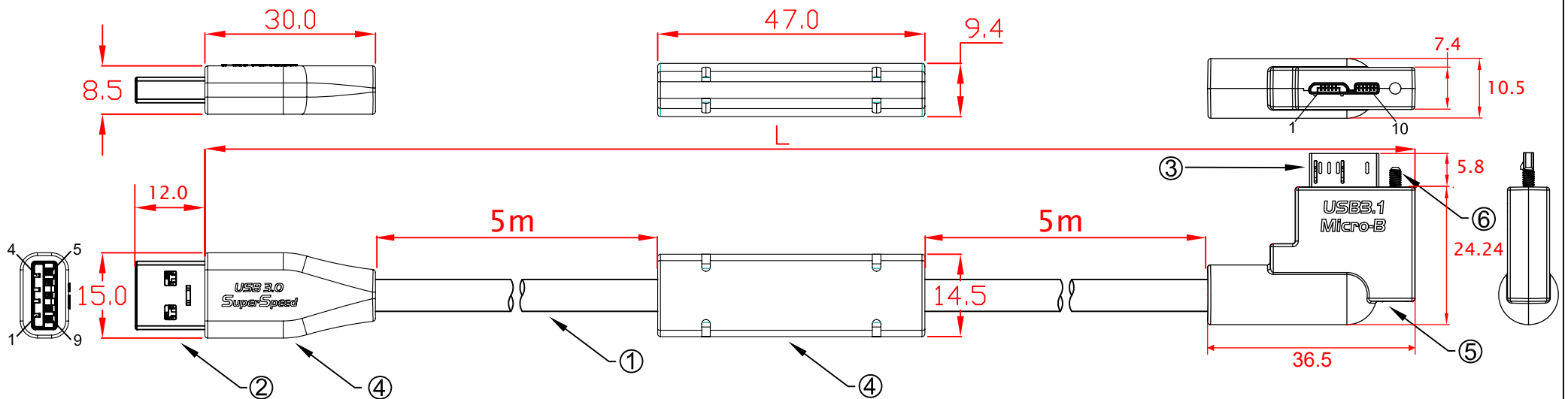

Operating Temperature: 0°C~70°C  
 Operating Humidity: 20%~80% (no condensation)  
 Storage Temperature: -25°C~85°C  
 Storage Humidity: 20%~80% (no condensation)

L:  
 CBL-D302MBSN-5mLA 5000mm±30mm  
 CBL-D302MBSN-7mLA 7000mm±30mm  
 CBL-D302MBSN-10mLA 10000mm±30mm

| No | MATERIALS LIST:  |
|----|--|
| 1. | CABLE:UL2725 (28AWG*1PR+D+AM)x2C+28AWG*1PR+24AWG*1C+AM+B OD:5.6mm PVC JACKET COLOR:BLACK |
| 2. | CONNECTOR:USB 3.0 A/M, 9P, BLUE INSULATOR SOLDER TYPE, NICKEL PLATED SHELL               |
| 3. | CONNECTOR:USB 3.0 MicroB/M, 10P, BLACK INSULATOR SOLDER TYPE, NICKEL PLATED SHELL        |
| 4. | PVC MOLDED HOUSING, BLACK COLOR  |
| 5. | ABS ASSEMBLY HOUSING, BLACK COLOR  |
| 6. | SCREW:#4x23.32 M2  |

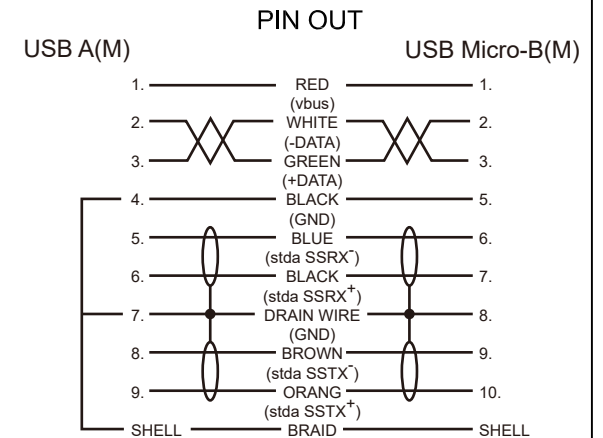

| Jargy part no.                | Client part no. | Approved | SCALE | UNIT |
|-------------------------------|-----------------|----------|-------|------|
| CBL-D302MBSN-xmLA             |                 |          |       | mm   |
| Drawing Name                  |                 | Drawn    | Date  | REV. |
| USB 3.0 A to MicroB Cable M/M |                 |          |       | 1.0  |

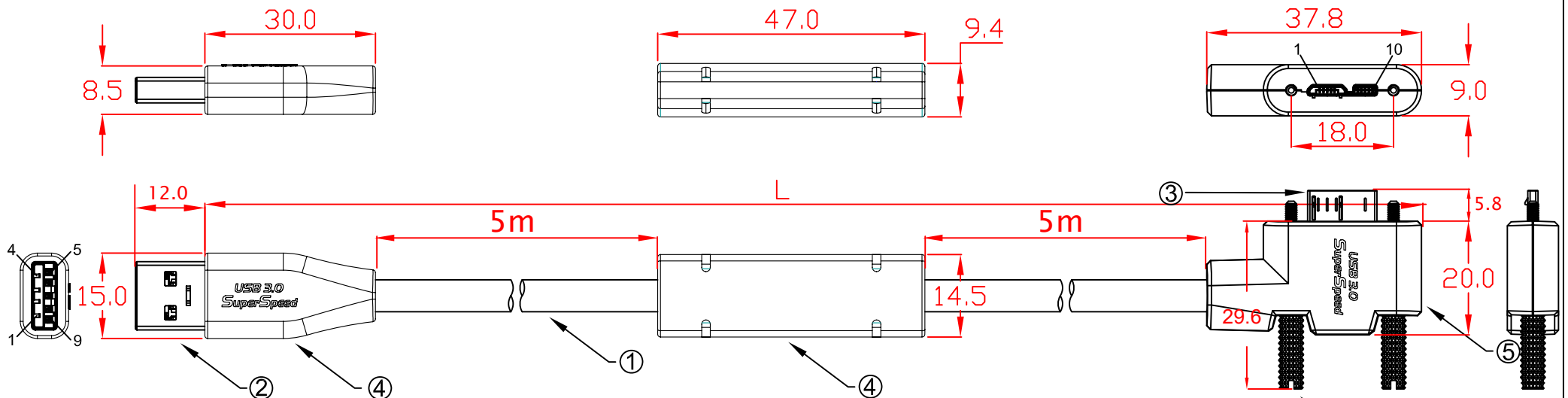

Operating Temperature: 0°C~70°C  
 Operating Humidity: 20%~80% (no condensation)  
 Storage Temperature: -25°C~85°C  
 Storage Humidity: 20%~80% (no condensation)

L:  
 CBL-D302MBS-5mLA 5000mm±30mm  
 CBL-D302MBS-7mLA 7000mm±30mm  
 CBL-D302MBS-10mLA 10000mm±30mm

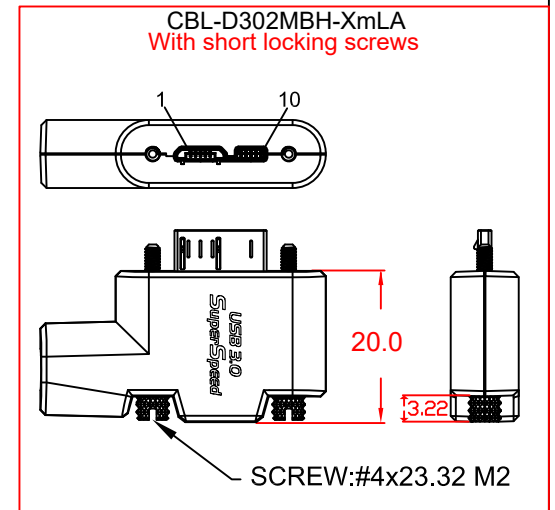
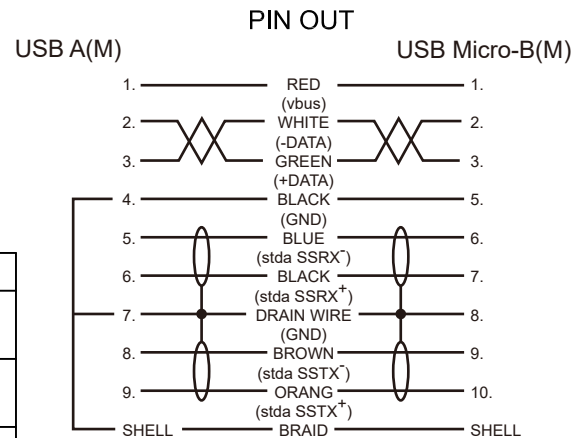

| No | MATERIALS LIST:  |
|----|--|
| 1. | CABLE:UL2725 (28AWG*1PR+D+AM)x2C+28AWG*1PR+24AWG*1C+AM+B OD:5.6mm PVC JACKET COLOR:BLACK |
| 2. | CONNECTOR:USB 3.0 A/M, 9P, BLUE INSULATOR SOLDER TYPE, NICKEL PLATED SHELL               |
| 3. | CONNECTOR:USB 3.0 MicroB/M, 10P, BLACK INSULATOR SOLDER TYPE, NICKEL PLATED SHELL        |
| 4. | PVC MOLDED HOUSING, BLACK COLOR  |
| 5. | ABS ASSEMBLY HOUSING, BLACK COLOR  |
| 6. | SCREW:#4x33 M2   |

| Jargy part no.                | Client part no. | Approved | SCALE | UNIT |
|-------------------------------|-----------------|----------|-------|------|
| CBL-D302MBS-XmLA              |                 |          |       | mm   |
| Drawing Name                  |                 | Drawn    | Date  | REV. |
| USB 3.0 A to MicroB Cable M/M |                 |          |       | 1.0  |

**Mobile Computing JARGY**

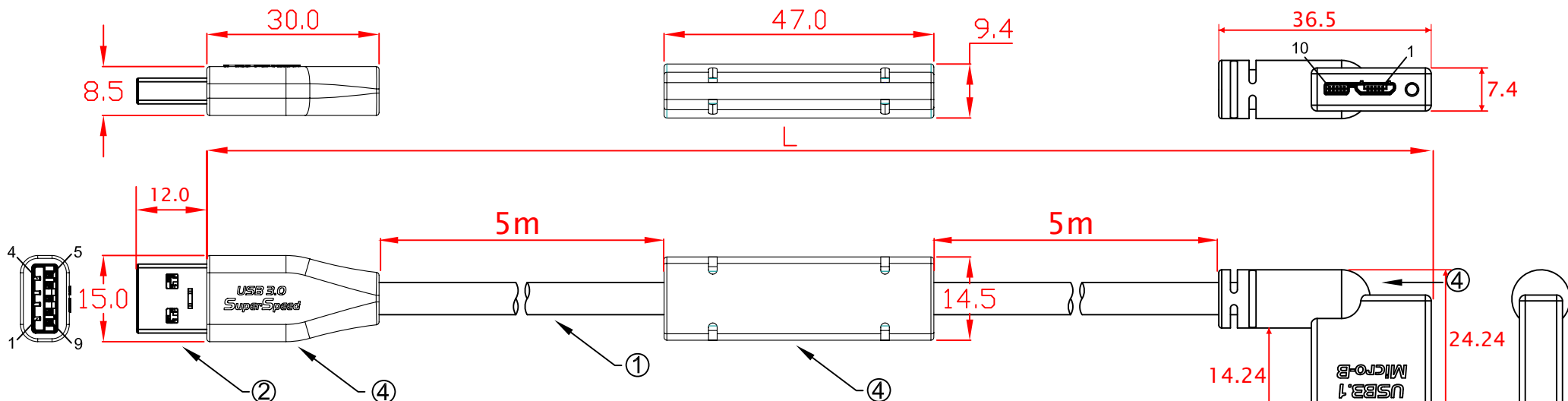

Operating Temperature: 0°C~70°C  
 Operating Humidity: 20%~80% (no condensation)  
 Storage Temperature: -25°C~85°C  
 Storage Humidity: 20%~80% (no condensation)

L:  
 CBL-D302MBHM-5mRA 5000mm±30mm  
 CBL-D302MBHM-7mRA 7000mm±30mm  
 CBL-D302MBHM-10mRA 10000mm±30mm

| No | MATERIALS LIST:  |
|----|--|
| 1. | CABLE:UL2725 (28AWG*1PR+D+AM)x2C+28AWG*1PR+24AWG*1C+AM+B OD:5.6mm PVC JACKET COLOR:BLACK |
| 2. | CONNECTOR:USB 3.0 A/M, 9P, BLUE INSULATOR SOLDER TYPE, NICKEL PLATED SHELL               |
| 3. | CONNECTOR:USB 3.0 MicroB/M, 10P, BLACK INSULATOR SOLDER TYPE, NICKEL PLATED SHELL        |
| 4. | PVC MOLDED HOUSING, BLACK COLOR  |
| 5. | SCREW:#4x23.32 M2  |
| 6. |  |

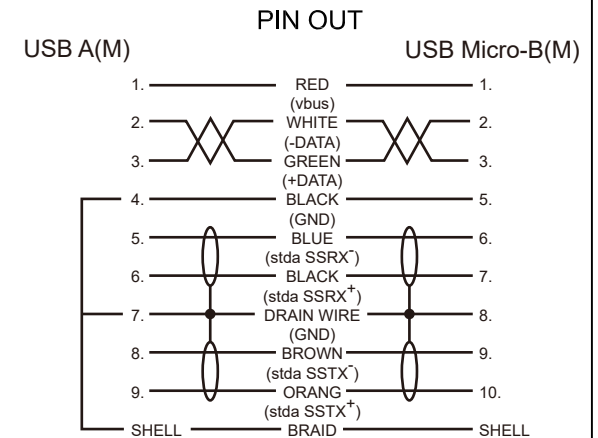

| Jargy part no.                | Client part no. | Approved | SCALE | UNIT |
|-------------------------------|-----------------|----------|-------|------|
| CBL-D302MBHM-xmRA             |                 |          |       | mm   |
| Drawing Name                  |                 | Drawn    | Date  | REV. |
| USB 3.0 A to MicroB Cable M/M |                 |          |       | 1.0  |

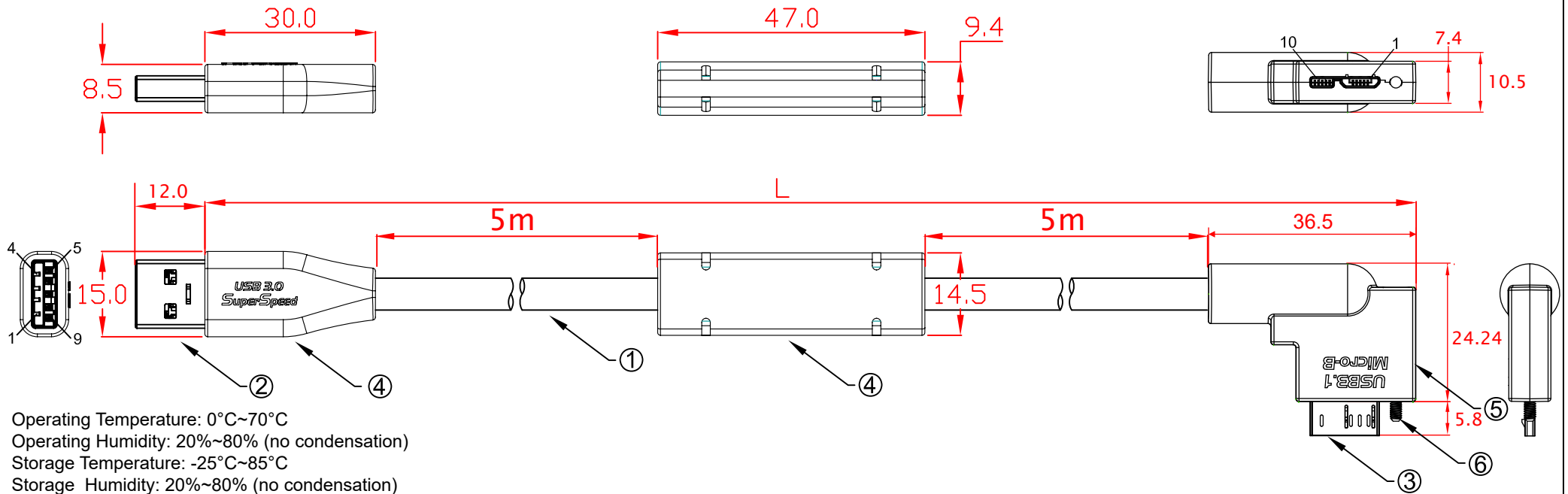

L:

- CBL-D302MBSN-5mRA 5000mm±30mm
- CBL-D302MBSN-7mRA 7000mm±30mm
- CBL-D302MBSN-10mRA 10000mm±30mm

| No | MATERIALS LIST:  |
|----|--|
| 1. | CABLE:UL2725 (28AWG*1PR+D+AM)x2C+28AWG*1PR+24AWG*1C+AM+B OD:5.6mm PVC JACKET COLOR:BLACK |
| 2. | CONNECTOR:USB 3.0 A/M, 9P, BLUE INSULATOR SOLDER TYPE, NICKEL PLATED SHELL               |
| 3. | CONNECTOR:USB 3.0 MicroB/M, 10P, BLACK INSULATOR SOLDER TYPE, NICKEL PLATED SHELL        |
| 4. | PVC MOLDED HOUSING, BLACK COLOR  |
| 5. | ABS ASSEMBLY HOUSING, BLACK COLOR  |
| 6. | SCREW:#4x23.32 M2  |

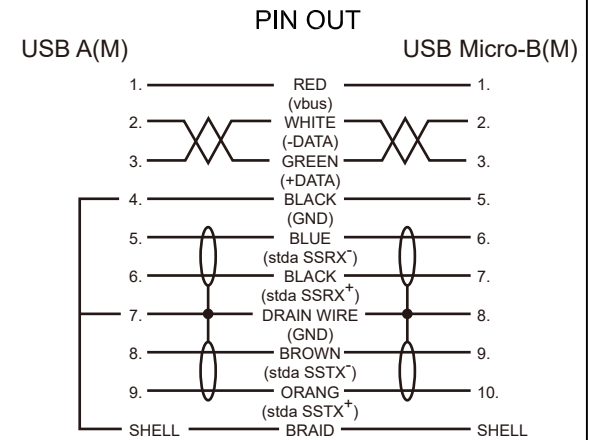

| Jargy part no.                | Client part no. | Approved | SCALE | UNIT |
|-------------------------------|-----------------|----------|-------|------|
| CBL-D302MBSN-XmRA             |                 |          |       | mm   |
| Drawing Name                  |                 | Drawn    | Date  | REV. |
| USB 3.0 A to MicroB Cable M/M |                 |          |       | 1.0  |

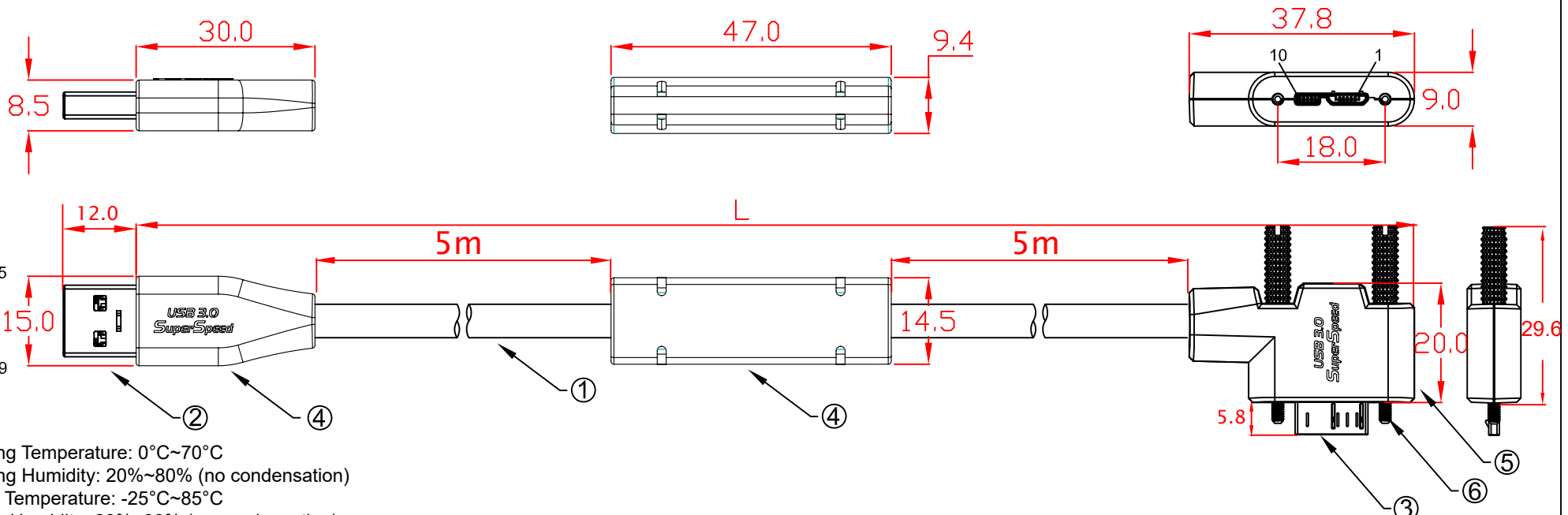

Operating Temperature: 0°C~70°C  
 Operating Humidity: 20%~80% (no condensation)  
 Storage Temperature: -25°C~85°C  
 Storage Humidity: 20%~80% (no condensation)

L:  
 CBL-D302MBS-5mRA 5000mm±30mm  
 CBL-D302MBS-7mRA 7000mm±30mm  
 CBL-D302MBS-10mRA 10000mm±30mm

| No | MATERIALS LIST:  |
|----|--|
| 1. | CABLE:UL2725 (28AWG*1PR+D+AM)x2C+28AWG*1PR+24AWG*1C+AM+B OD:5.6mm PVC JACKET COLOR:BLACK |
| 2. | CONNECTOR:USB 3.0 A/M, 9P, BLUE INSULATOR SOLDER TYPE, NICKEL PLATED SHELL               |
| 3. | CONNECTOR:USB 3.0 MicroB/M, 10P, BLACK INSULATOR SOLDER TYPE, NICKEL PLATED SHELL        |
| 4. | PVC MOLDED HOUSING, BLACK COLOR  |
| 5. | ABS ASSEMBLY HOUSING, BLACK COLOR  |
| 6. | SCREW:#4x33 M2   |

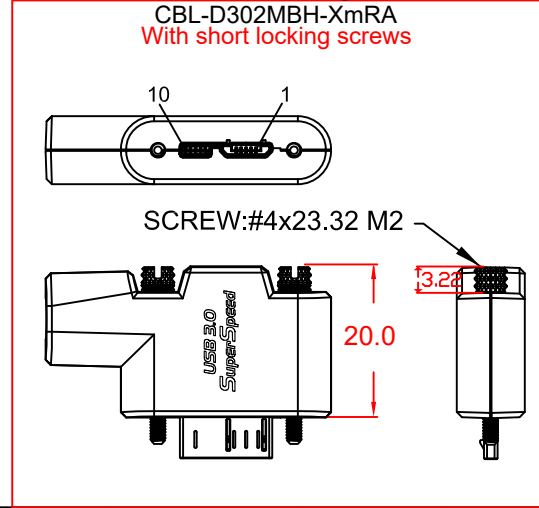
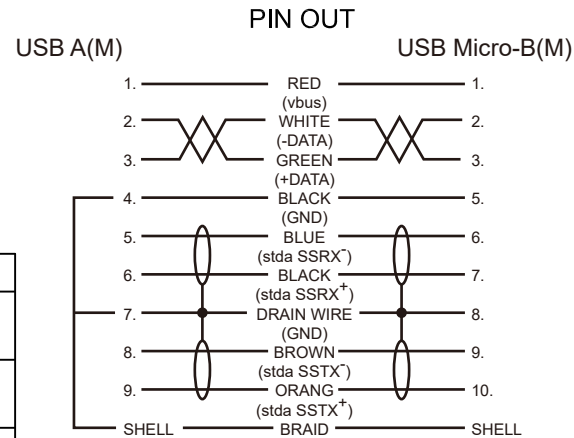

| Jargy part no.                | Client part no. | Approved | SCALE | UNIT |
|-------------------------------|-----------------|----------|-------|------|
| CBL-D302MBS-XmRA              |                 |          |       | mm   |
| Drawing Name                  |                 | Drawn    | Date  | REV. |
| USB 3.0 A to MicroB Cable M/M |                 |          |       | 1.0  |



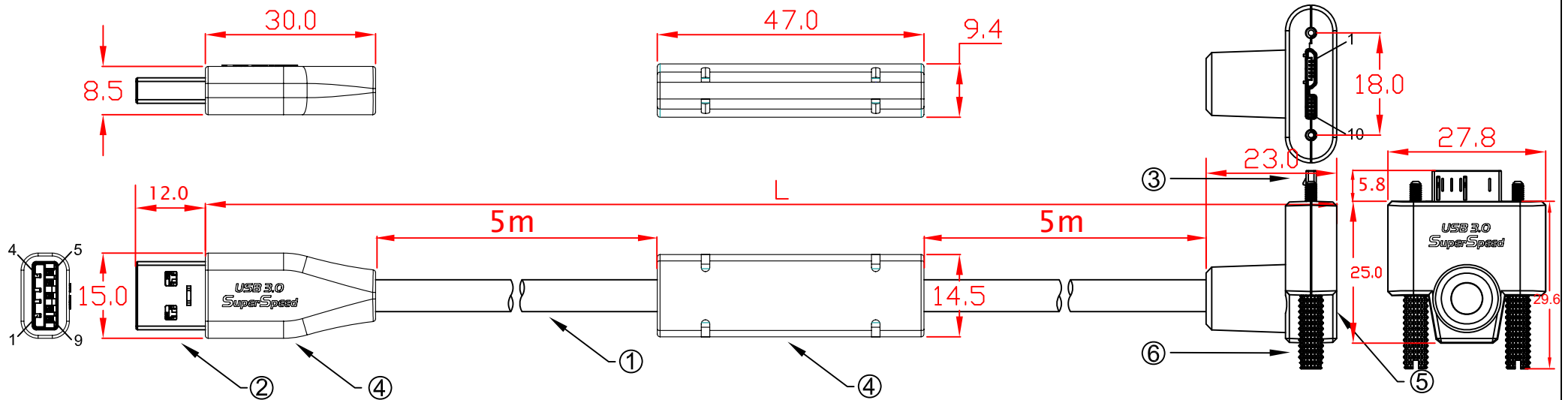

Operating Temperature: 0°C~70°C  
 Operating Humidity: 20%~80% (no condensation)  
 Storage Temperature: -25°C~85°C  
 Storage Humidity: 20%~80% (no condensation)

L:  
 CBL-D302MBS-5mUA 5000mm±30mm  
 CBL-D302MBS-7mUA 7000mm±30mm  
 CBL-D302MBS-10mUA 10000mm±30mm

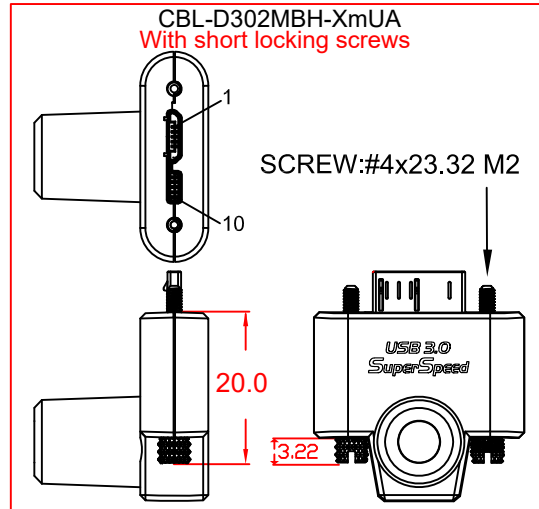
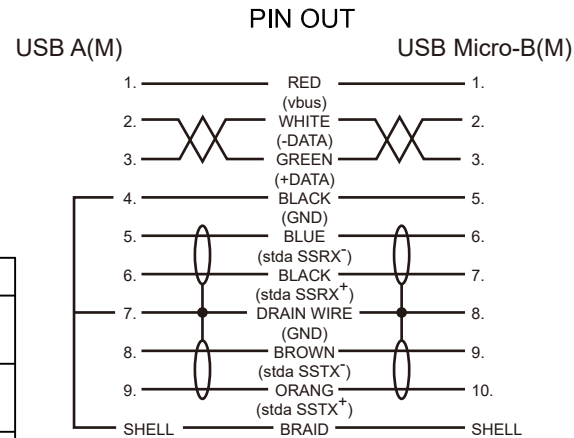

| No | MATERIALS LIST:  |
|----|--|
| 1. | CABLE:UL2725 (28AWG*1PR+D+AM)x2C+28AWG*1PR+24AWG*1C+AM+B OD:5.6mm PVC JACKET COLOR:BLACK |
| 2. | CONNECTOR:USB 3.0 A/M, 9P, BLUE INSULATOR SOLDER TYPE, NICKEL PLATED SHELL               |
| 3. | CONNECTOR:USB 3.0 MicroB/M, 10P, BLACK INSULATOR SOLDER TYPE, NICKEL PLATED SHELL        |
| 4. | PVC MOLDED HOUSING, BLACK COLOR  |
| 5. | ABS ASSEMBLY HOUSING, BLACK COLOR  |
| 6. | SCREW:#4x33 M2   |

| Jargy part no.                | Client part no. | Approved | SCALE | UNIT |
|-------------------------------|-----------------|----------|-------|------|
| CBL-D302MBS-XmUA              |                 |          |       | mm   |
| Drawing Name                  |                 | Drawn    | Date  | REV. |
| USB 3.0 A to MicroB Cable M/M |                 |          |       | 1.0  |

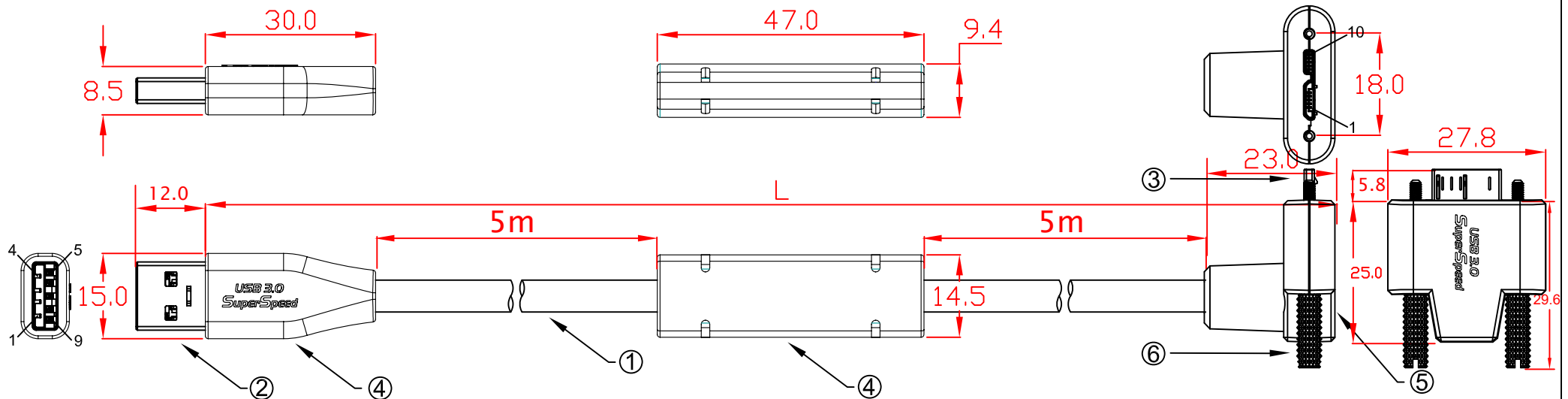

Operating Temperature: 0°C~70°C  
 Operating Humidity: 20%~80% (no condensation)  
 Storage Temperature: -25°C~85°C  
 Storage Humidity: 20%~80% (no condensation)

L:

CBL-D302MBS-5mDA 5000mm±30mm  
 CBL-D302MBS-7mDA 7000mm±30mm  
 CBL-D302MBS-10mDA 10000mm±30mm

| No | MATERIALS LIST:  |
|----|--|
| 1. | CABLE:UL2725 (28AWG*1PR+D+AM)x2C+28AWG*1PR+24AWG*1C+AM+B OD:5.6mm PVC JACKET COLOR:BLACK |
| 2. | CONNECTOR:USB 3.0 A/M, 9P, BLUE INSULATOR SOLDER TYPE, NICKEL PLATED SHELL               |
| 3. | CONNECTOR:USB 3.0 MicroB/M, 10P, BLACK INSULATOR SOLDER TYPE, NICKEL PLATED SHELL        |
| 4. | PVC MOLDED HOUSING, BLACK COLOR  |
| 5. | ABS ASSEMBLY HOUSING, BLACK COLOR  |
| 6. | SCREW:#4x33 M2   |

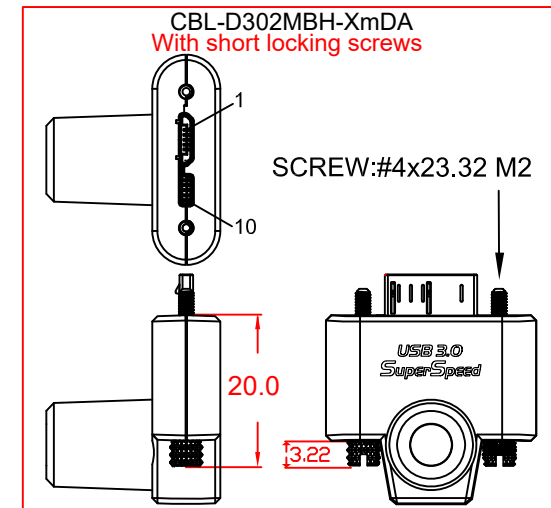
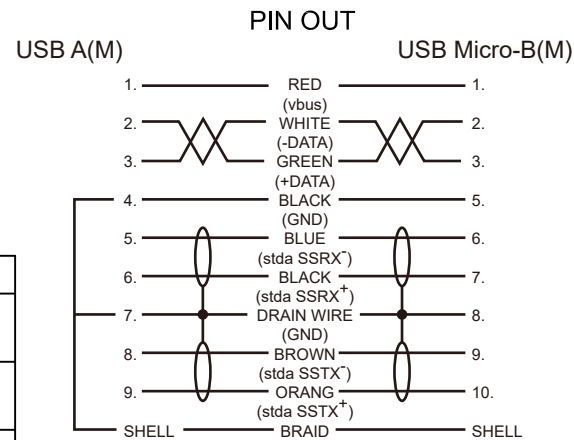

| Jargy part no.                | Client part no. | Approved | SCALE | UNIT |
|-------------------------------|-----------------|----------|-------|------|
| CBL-D302MBS-XmDA              |                 |          |       | mm   |
| Drawing Name                  |                 | Drawn    | Date  | REV. |
| USB 3.0 A to MicroB Cable M/M |                 |          |       | 1.0  |



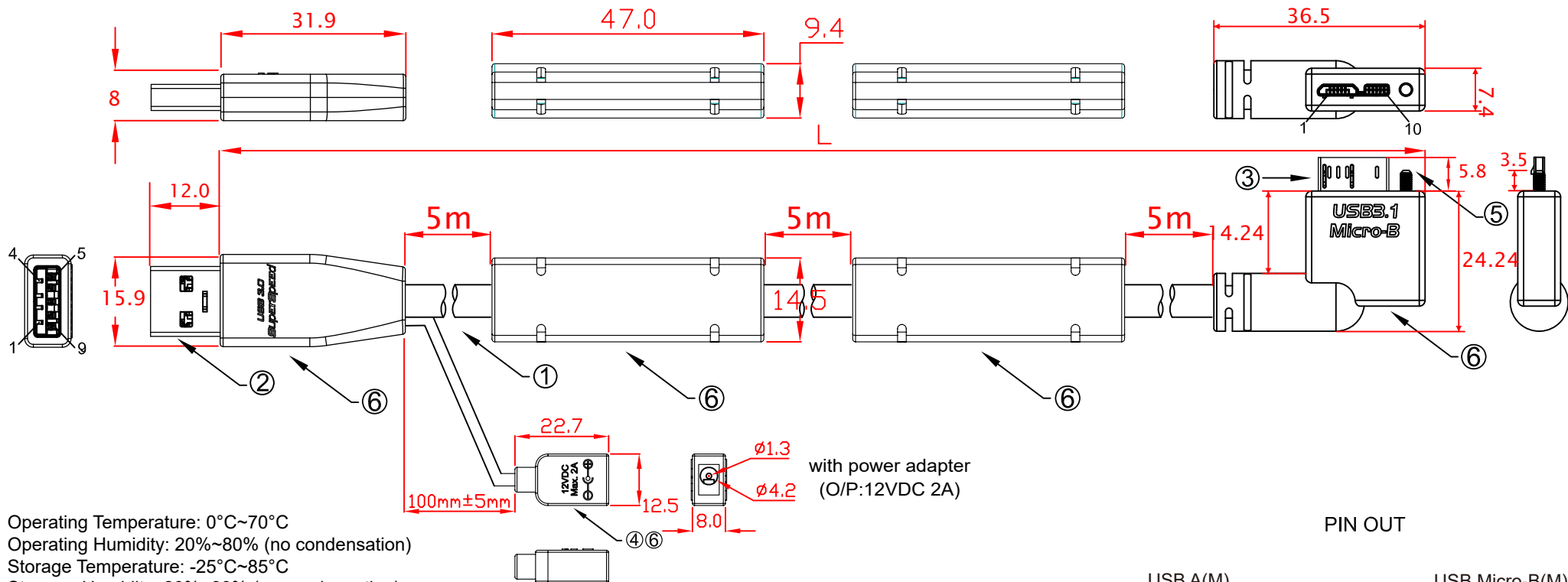

Operating Temperature: 0°C~70°C  
 Operating Humidity: 20%~80% (no condensation)  
 Storage Temperature: -25°C~85°C  
 Storage Humidity: 20%~80% (no condensation)

L:  
 CBL-D302MBHMWBPW-15mLA 15000mm±50mm

| No | MATERIALS LIST:  |
|----|--|
| 1. | CABLE:UL2725 (28AWG*1PR+D+AM)x2C+28AWG*1PR+24AWG*1C+AM+B OD:5.6mm PVC JACKET COLOR:BLACK |
| 2. | CONNECTOR:USB 3.0 A/M, 9P, BLUE INSULATOR SOLDER TYPE, NICKEL PLATED SHELL               |
| 3. | CONNECTOR:USB 3.0 MicroB/M, 10P, BLACK INSULATOR SOLDER TYPE, NICKEL PLATED SHELL        |
| 4. | DC JACK 1.3mm 30V 0.3V   |
| 5. | SCREW:#4x23.32 M2  |
| 6. | PVC MOLDED HOUSING, BLACK COLOR  |
| 7. |  |

PIN OUT

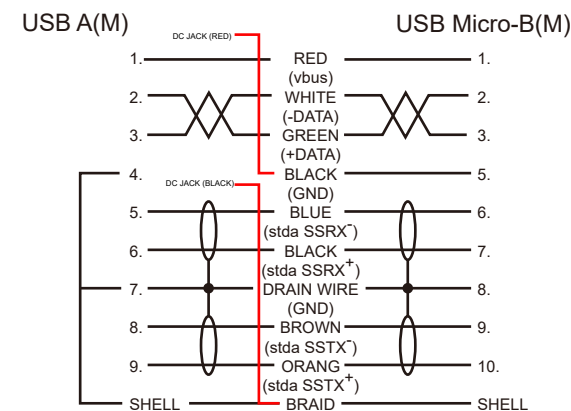

| Jargy part no.                | Client part no. | Approved | SCALE | UNIT |
|-------------------------------|-----------------|----------|-------|------|
| CBL-D302MBHMWBPW-xmlA         |                 |          |       | mm   |
| Drawing Name                  |                 | Drawn    | Date  | REV. |
| USB 3.0 A to MicroB Cable M/M |                 |          |       | 1.0  |

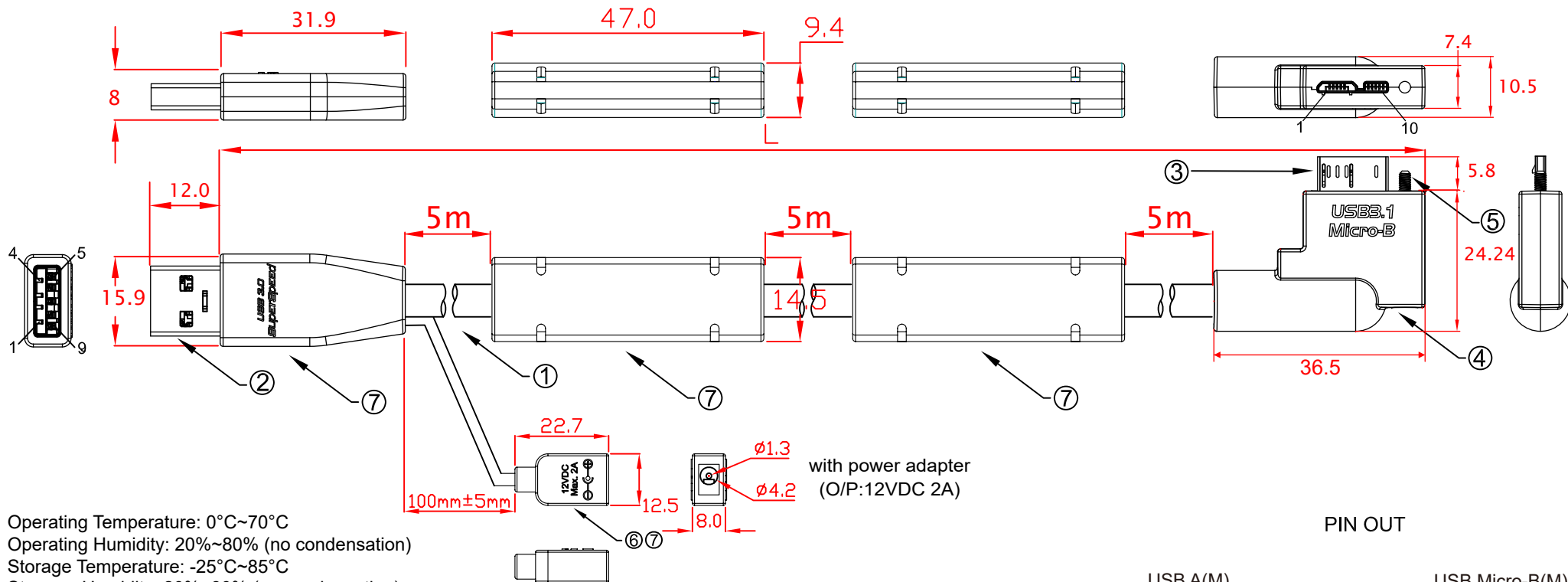

Operating Temperature: 0°C~70°C  
 Operating Humidity: 20%~80% (no condensation)  
 Storage Temperature: -25°C~85°C  
 Storage Humidity: 20%~80% (no condensation)

with power adapter  
 (O/P:12VDC 2A)

L:  
 CBL-D302MBSNWBPW-15mLA 15000mm±50mm

**PIN OUT**

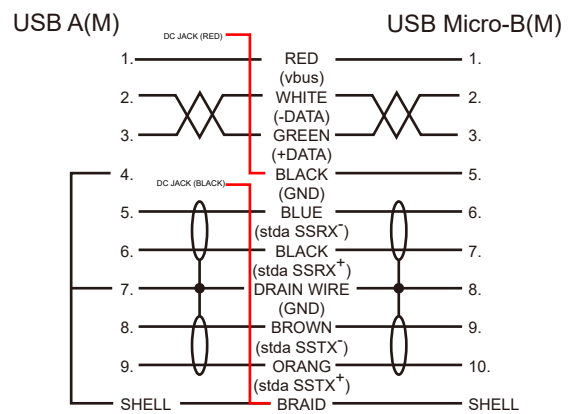

| No | MATERIALS LIST:  |
|----|--|
| 1. | CABLE:UL2725 (28AWG*1PR+D+AM)x2C+28AWG*1PR+24AWG*1C+AM+B OD:5.6mm PVC JACKET COLOR:BLACK |
| 2. | CONNECTOR:USB 3.0 A/M, 9P, BLUE INSULATOR SOLDER TYPE, NICKEL PLATED SHELL               |
| 3. | CONNECTOR:USB 3.0 MicroB/M, 10P, BLACK INSULATOR SOLDER TYPE, NICKEL PLATED SHELL        |
| 4. | ABS HOUSING, BLACK COLOR   |
| 5. | SCREW:#4x23.32 M2  |
| 6. | DC JACK 1.3mm 30V 0.3V   |
| 7. | PVC MOLDED HOUSING, BLACK COLOR  |

| Jargy part no.                | Client part no. | Approved | SCALE | UNIT |
|-------------------------------|-----------------|----------|-------|------|
| CBL-D302MBSNWBPW-xmlA         |                 |          |       | mm   |
| Drawing Name                  |                 | Drawn    | Date  | REV. |
| USB 3.0 A to MicroB Cable M/M |                 |          |       | 1.0  |



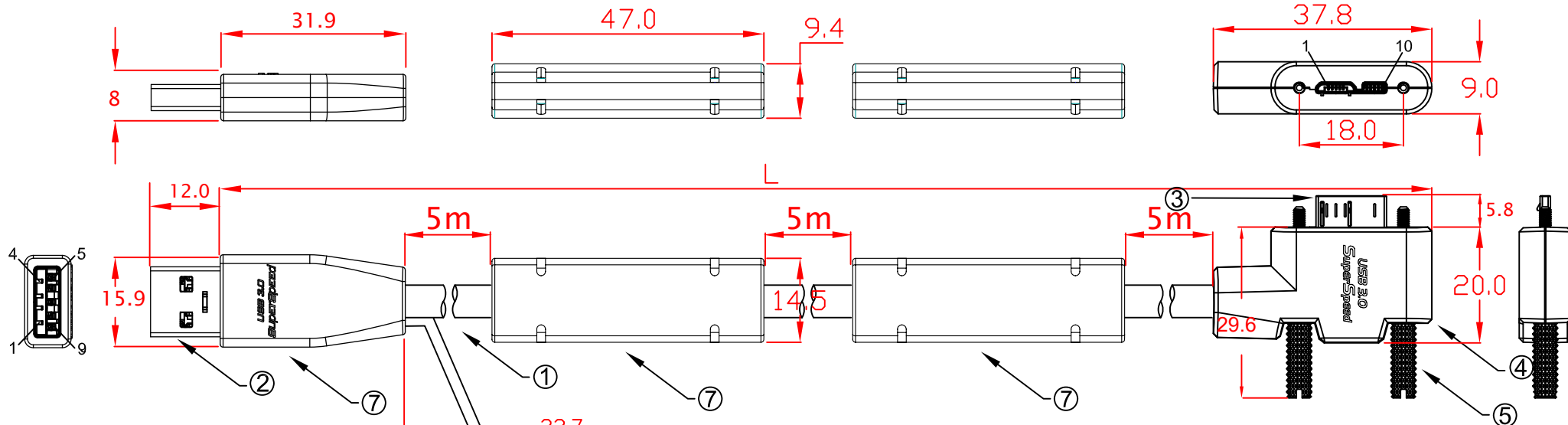

Operating Temperature: 0°C~70°C  
 Operating Humidity: 20%~80% (no condensation)  
 Storage Temperature: -25°C~85°C  
 Storage Humidity: 20%~80% (no condensation)

CBL-D302MBSWBPW-15mLA 15000mm±50mm

| No | MATERIALS LIST:  |
|----|--|
| 1. | CABLE:UL2725 (28AWG*1PR+D+AM)x2C+28AWG*1PR+24AWG*1C+AM+B OD:5.6mm PVC JACKET COLOR:BLACK |
| 2. | CONNECTOR:USB 3.0 A/M, 9P, BLUE INSULATOR SOLDER TYPE, NICKEL PLATED SHELL               |
| 3. | CONNECTOR:USB 3.0 MicroB/M, 10P, BLACK INSULATOR SOLDER TYPE, NICKEL PLATED SHELL        |
| 4. | ABS HOUSING, BLACK COLOR   |
| 5. | SCREW:#4x33 M2   |
| 6. | DC JACK 1.3mm 30V 0.3V   |
| 7. | PVC MOLDED HOUSING, BLACK COLOR  |

with power adapter  
(O/P:12VDC 2A)

PIN OUT

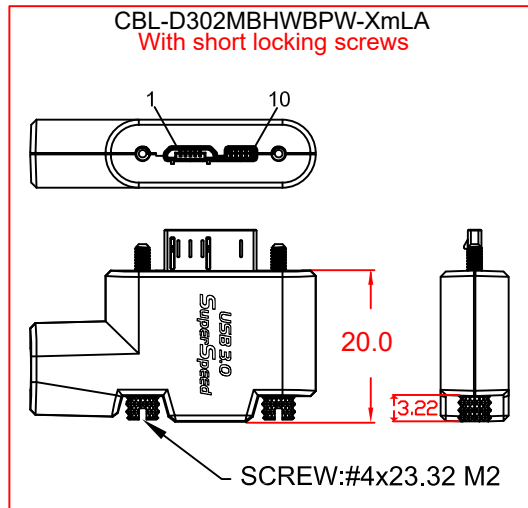
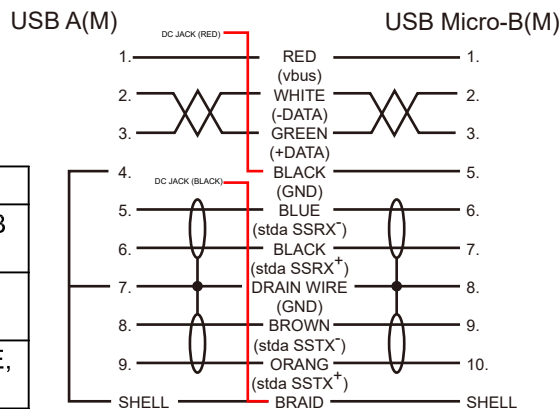

| Jargy part no.                | Client part no. | Approved | SCALE | UNIT |
|-------------------------------|-----------------|----------|-------|------|
| CBL-D302MBSWBPW-15mLA         |                 |          |       | mm   |
| Drawing Name                  |                 | Drawn    | Date  | REV. |
| USB 3.0 A to MicroB Cable M/M |                 |          |       | 1.0  |



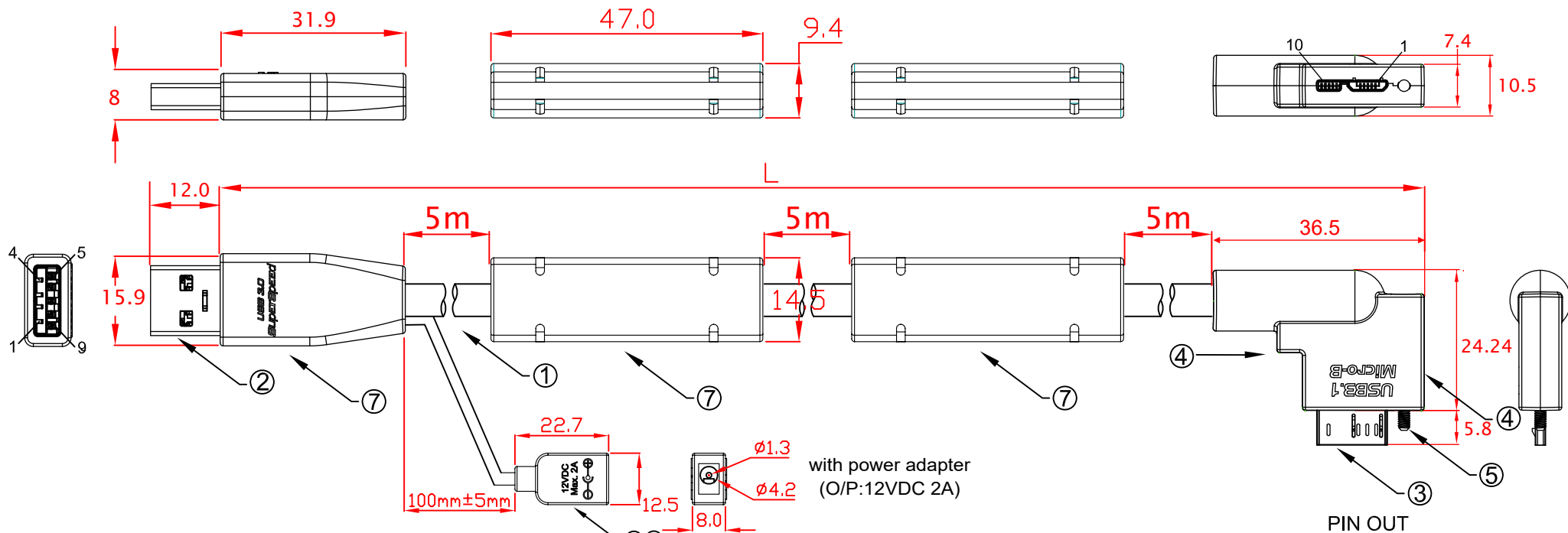

Operating Temperature: 0°C~70°C  
 Operating Humidity: 20%~80% (no condensation)  
 Storage Temperature: -25°C~85°C  
 Storage Humidity: 20%~80% (no condensation)

CBL-D302MBSNWPW-15mRA 15000mm±50mm

| No | MATERIALS LIST:  |
|----|--|
| 1. | CABLE:UL2725 (28AWG*1PR+D+AM)x2C+28AWG*1PR+24AWG*1C+AM+B OD:5.6mm PVC JACKET COLOR:BLACK |
| 2. | CONNECTOR:USB 3.0 A/M, 9P, BLUE INSULATOR SOLDER TYPE, NICKEL PLATED SHELL               |
| 3. | CONNECTOR:USB 3.0 MicroB/M, 10P, BLACK INSULATOR SOLDER TYPE, NICKEL PLATED SHELL        |
| 4. | ABS HOUSING, BLACK COLOR   |
| 5. | SCREW:#4x23.32 M2  |
| 6. | DC JACK 1.3mm 30V 0.3V   |
| 7. | PVC MOLDED HOUSING, BLACK COLOR  |

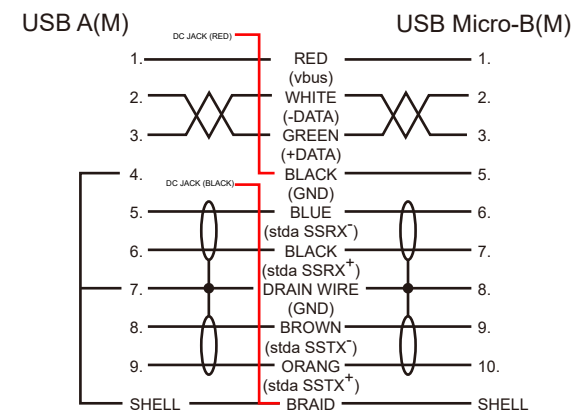

| Jargy part no.                | Client part no. | Approved | SCALE | UNIT |
|-------------------------------|-----------------|----------|-------|------|
| CBL-D302MBSNWPW-15mRA         |                 |          |       | mm   |
| Drawing Name                  |                 | Drawn    | Date  | REV. |
| USB 3.0 A to MicroB Cable M/M |                 |          |       | 1.0  |



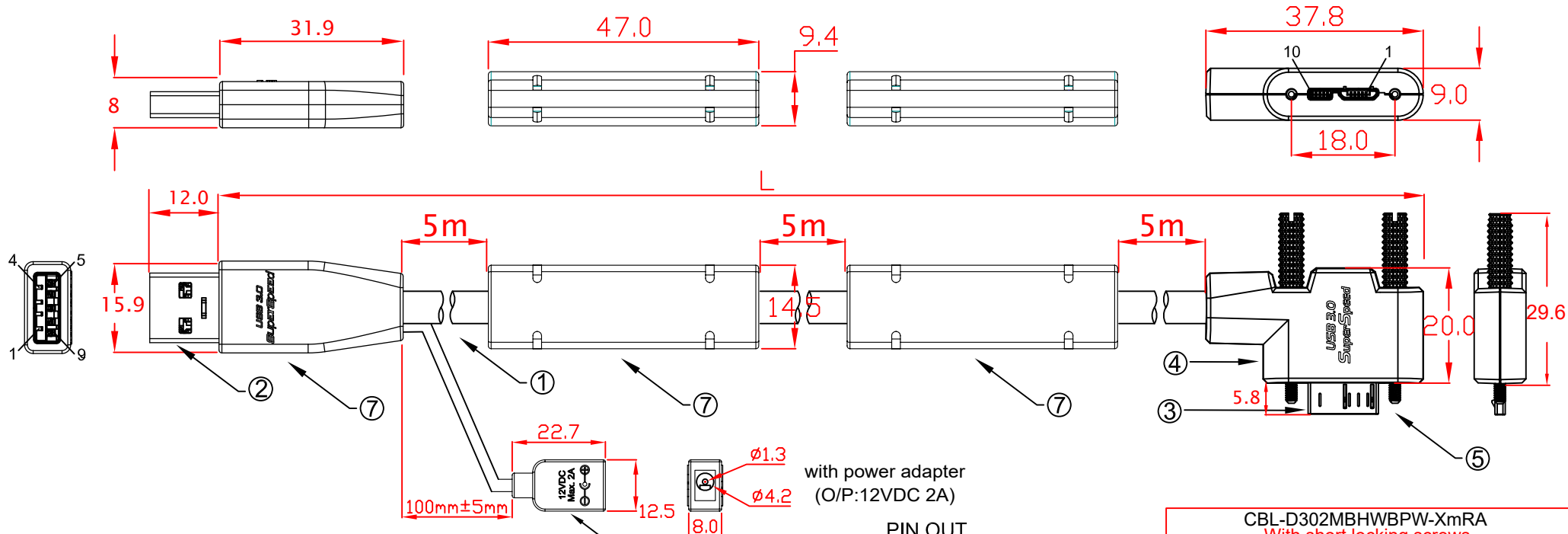

Operating Temperature: 0°C~70°C  
 Operating Humidity: 20%~80% (no condensation)  
 Storage Temperature: -25°C~85°C  
 Storage Humidity: 20%~80% (no condensation)

CBL-D302MBSWBPW-15mRA 15000mm±50mm

| No | MATERIALS LIST:  |
|----|--|
| 1. | CABLE:UL2725 (28AWG*1PR+D+AM)x2C+28AWG*1PR+24AWG*1C+AM+B OD:5.6mm PVC JACKET COLOR:BLACK |
| 2. | CONNECTOR:USB 3.0 A/M, 9P, BLUE INSULATOR SOLDER TYPE, NICKEL PLATED SHELL               |
| 3. | CONNECTOR:USB 3.0 MicroB/M, 10P, BLACK INSULATOR SOLDER TYPE, NICKEL PLATED SHELL        |
| 4. | ABS HOUSING, BLACK COLOR   |
| 5. | SCREW:#4x33 M2   |
| 6. | DC JACK 1.3mm 30V 0.3V   |
| 7. | PVC MOLDED HOUSING, BLACK COLOR  |

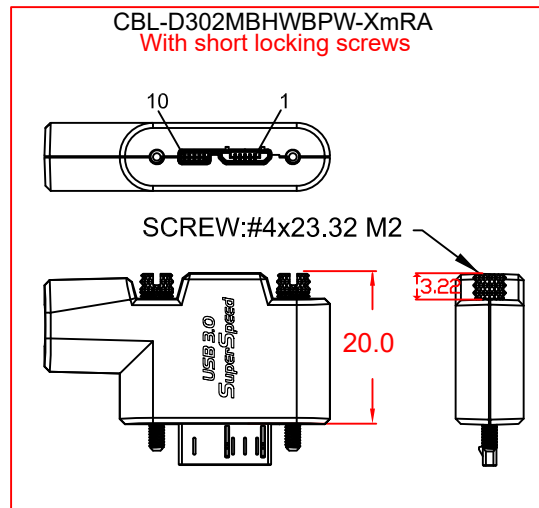
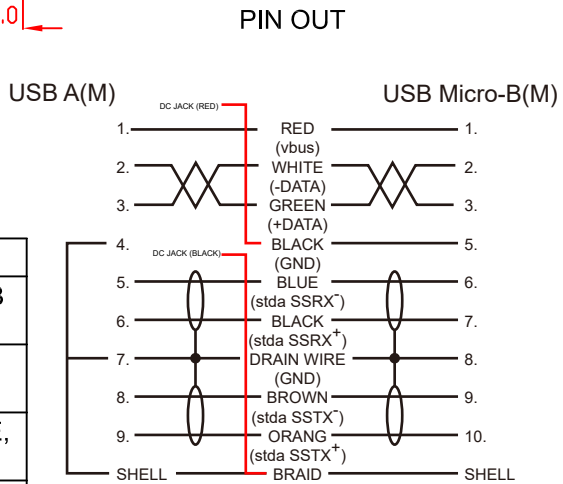

| Jargy part no.                | Client part no. | Approved | SCALE | UNIT |
|-------------------------------|-----------------|----------|-------|------|
| CBL-D302MBSWBPW-15mRA         |                 |          |       | mm   |
| Drawing Name                  |                 | Drawn    | Date  | REV. |
| USB 3.0 A to MicroB Cable M/M |                 |          |       | 1.0  |

**Mobile Computing** **JARGY**

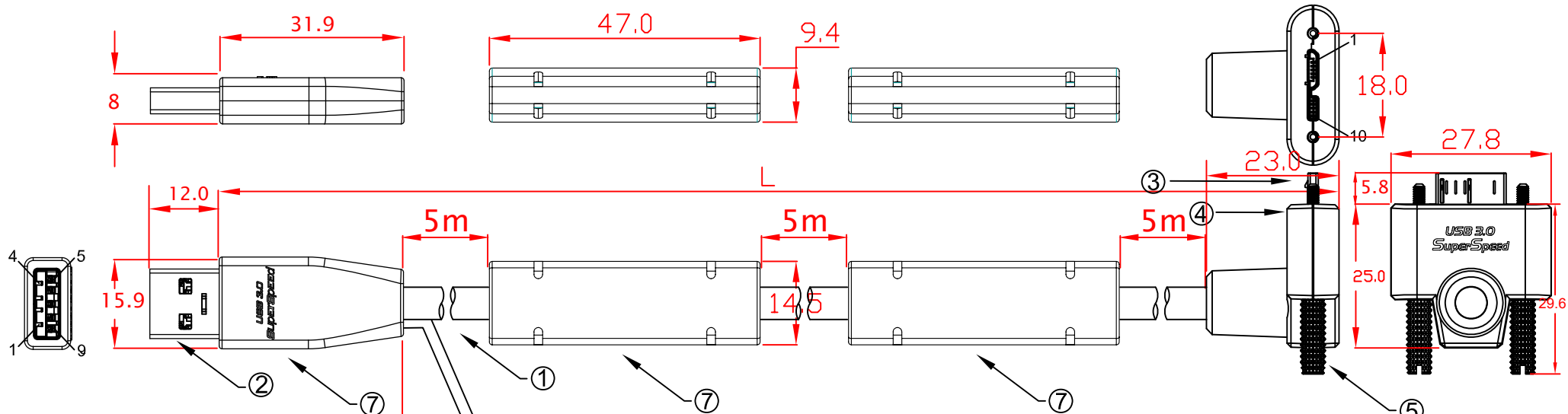

Operating Temperature: 0°C~70°C  
 Operating Humidity: 20%~80% (no condensation)  
 Storage Temperature: -25°C~85°C  
 Storage Humidity: 20%~80% (no condensation)

CBL-D302MBSWBPW-15mUA 15000mm±50mm

| No | MATERIALS LIST:  |
|----|--|
| 1. | CABLE:UL2725 (28AWG*1PR+D+AM)x2C+28AWG*1PR+24AWG*1C+AM+B OD:5.6mm PVC JACKET COLOR:BLACK |
| 2. | CONNECTOR:USB 3.0 A/M, 9P, BLUE INSULATOR SOLDER TYPE, NICKEL PLATED SHELL               |
| 3. | CONNECTOR:USB 3.0 MicroB/M, 10P, BLACK INSULATOR SOLDER TYPE, NICKEL PLATED SHELL        |
| 4. | ABS HOUSING, BLACK COLOR   |
| 5. | SCREW:#4x33 M2   |
| 6. | DC JACK 1.3mm 30V 0.3V   |
| 7. | PVC MOLDED HOUSING, BLACK COLOR  |

with power adapter  
(O/P:12VDC 2A)

PIN OUT

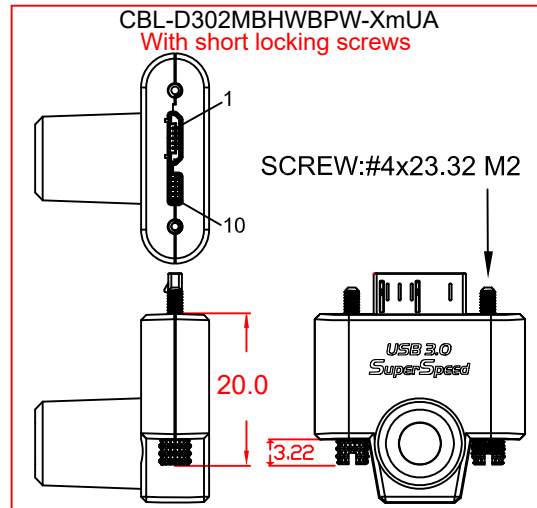
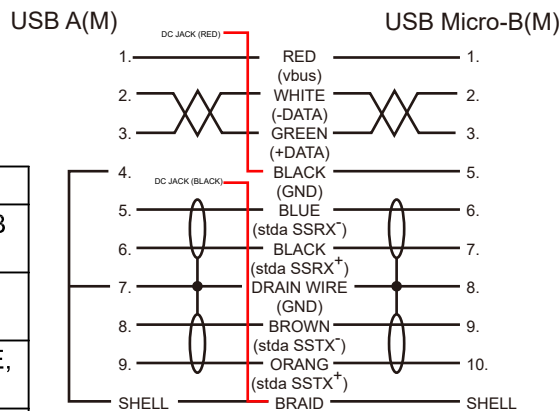

| Jargy part no.                | Client part no. | Approved | SCALE | UNIT |
|-------------------------------|-----------------|----------|-------|------|
| CBL-D302MBSWBPW-15mUA         |                 |          |       | mm   |
| Drawing Name                  |                 | Drawn    | Date  | REV. |
| USB 3.0 A to MicroB Cable M/M |                 |          |       | 1.0  |

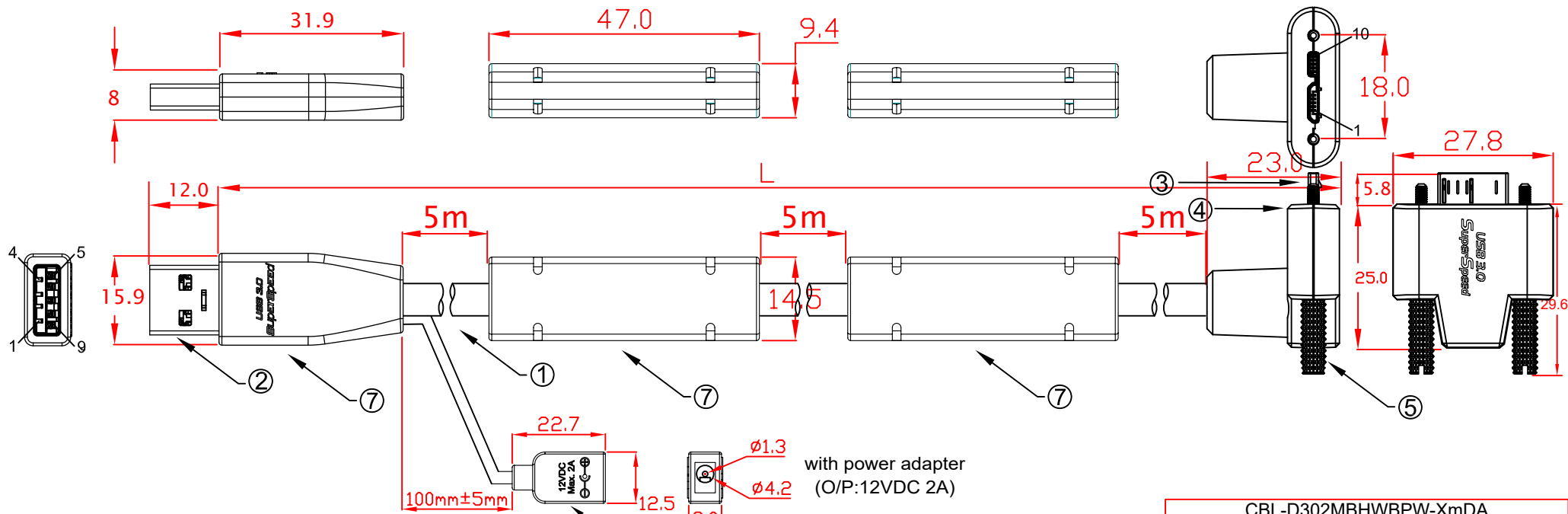

Operating Temperature: 0°C~70°C  
 Operating Humidity: 20%~80% (no condensation)  
 Storage Temperature: -25°C~85°C  
 Storage Humidity: 20%~80% (no condensation)

with power adapter  
 (O/P:12VDC 2A)

PIN OUT

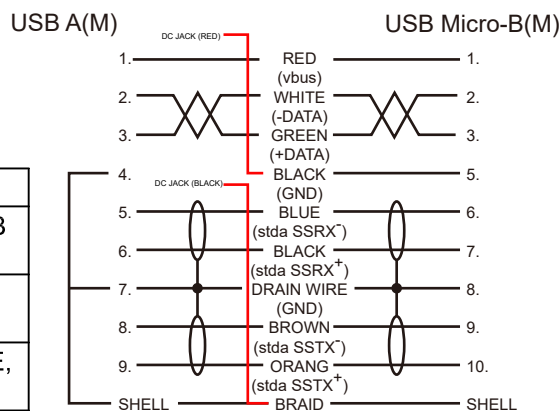

CBL-D302MBHWBPW-XmDA  
 With short locking screws

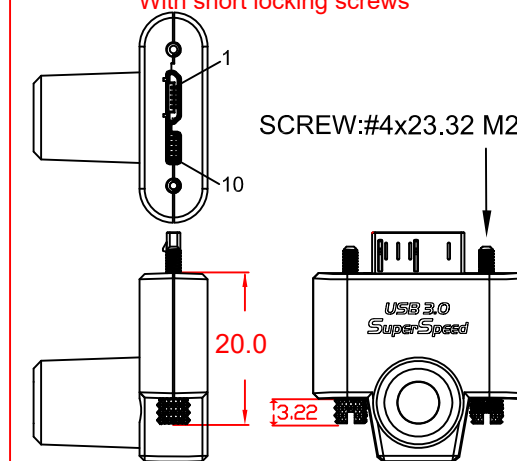

CBL-D302MBSWBPW-15mDA 15000mm±50mm

| No | MATERIALS LIST:  |
|----|--|
| 1. | CABLE:UL2725 (28AWG*1PR+D+AM)x2C+28AWG*1PR+24AWG*1C+AM+B OD:5.6mm PVC JACKET COLOR:BLACK |
| 2. | CONNECTOR:USB 3.0 A/M, 9P, BLUE INSULATOR SOLDER TYPE, NICKEL PLATED SHELL               |
| 3. | CONNECTOR:USB 3.0 MicroB/M, 10P, BLACK INSULATOR SOLDER TYPE, NICKEL PLATED SHELL        |
| 4. | ABS HOUSING, BLACK COLOR   |
| 5. | SCREW:#4x33 M2   |
| 6. | DC JACK 1.3mm 30V 0.3V   |
| 7. | PVC MOLDED HOUSING, BLACK COLOR  |

| Jargy part no.                | Client part no. | Approved | SCALE | UNIT |
|-------------------------------|-----------------|----------|-------|------|
| CBL-D302MBSWBPW-15mDA         |                 |          |       | mm   |
| Drawing Name                  |                 | Drawn    | Date  | REV. |
| USB 3.0 A to MicroB Cable M/M |                 |          |       | 1.0  |

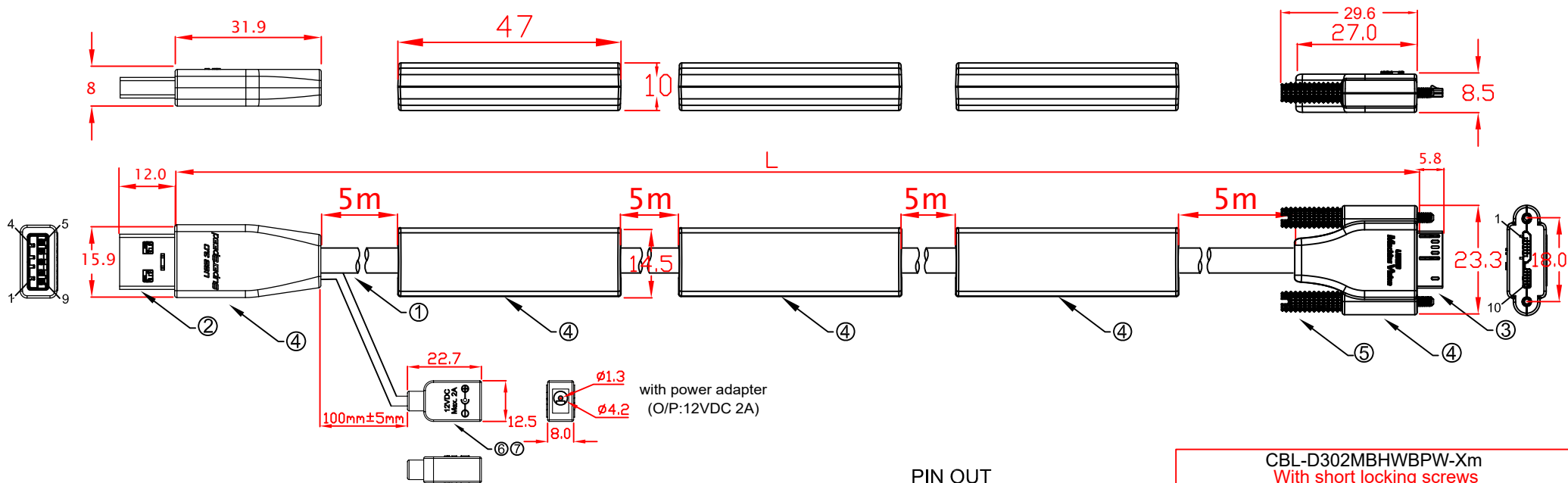

Operating Temperature: 0°C~70°C  
 Operating Humidity: 20%~80% (no condensation)  
 Storage Temperature: -25°C~85°C  
 Storage Humidity: 20%~80% (no condensation)

L:  
 CBL-D302MBSWBPW-20m 20000mm±50mm

| No | MATERIALS LIST:  |
|----|--|
| 1. | CABLE:UL2725 (28AWG*1PR+D+AM)x2C+28AWG*1PR+24AWG*1C+AM+B OD:5.6mm PVC JACKET COLOR:BLACK |
| 2. | CONNECTOR:USB 3.0 A/M, 9P, BLUE INSULATOR SOLDER TYPE, NICKEL PLATED SHELL               |
| 3. | CONNECTOR:USB 3.0 MicroB/M, 10P, BLACK INSULATOR SOLDER TYPE, NICKEL PLATED SHELL        |
| 4. | ABS HOUSING, BLACK COLOR   |
| 5. | SCREW:#4x33 M2   |
| 6. | DC JACK 1.3mm 30V 0.3V   |
| 7. | PVC MOLDED HOUSING, BLACK COLOR  |

### PIN OUT

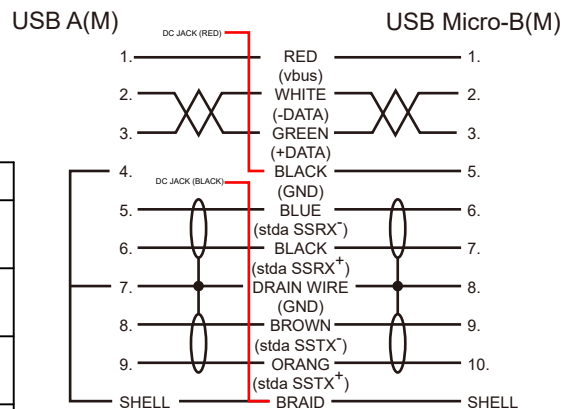

### CBL-D302MBHWBPW-Xm With short locking screws

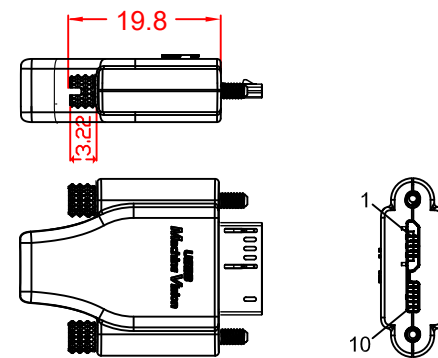

| Jargy part no.                | Client part no. | Approved | SCALE | UNIT |
|-------------------------------|-----------------|----------|-------|------|
| CBL-D302MBSWBPW-20m           |                 |          |       | mm   |
| Drawing Name                  |                 | Drawn    | Date  | REV. |
| USB 3.0 A to MicroB Cable M/M |                 |          |       | 1.0  |

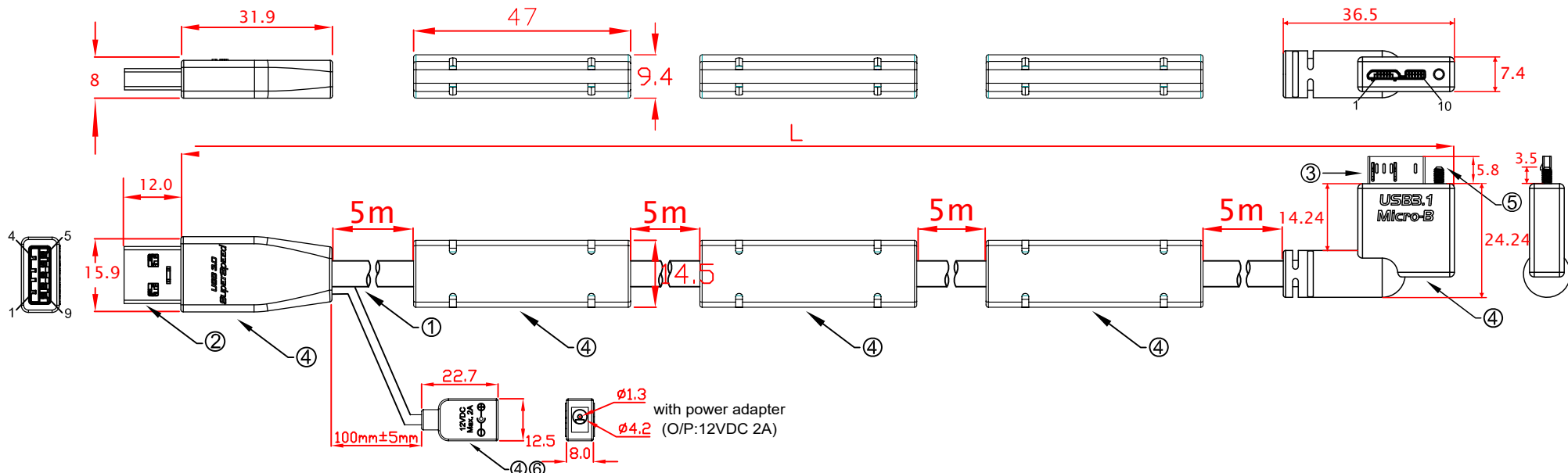

Operating Temperature: 0°C~70°C  
 Operating Humidity: 20%~80% (no condensation)  
 Storage Temperature: -25°C~85°C  
 Storage Humidity: 20%~80% (no condensation)

L:  
 CBL-D302MBHMWBPW-20mLA 20000mm±50mm

| No | MATERIALS LIST:  |
|----|--|
| 1. | CABLE:UL2725 (28AWG*1PR+D+AM)x2C+28AWG*1PR+24AWG*1C+AM+B OD:5.6mm PVC JACKET COLOR:BLACK |
| 2. | CONNECTOR:USB 3.0 A/M, 9P, BLUE INSULATOR SOLDER TYPE, NICKEL PLATED SHELL               |
| 3. | CONNECTOR:USB 3.0 MicroB/M, 10P, BLACK INSULATOR SOLDER TYPE, NICKEL PLATED SHELL        |
| 4. | PVC MOLDED HOUSING, BLACK COLOR  |
| 5. | SCREW:#4x23.32 M2  |
| 6. | DC JACK 1.3mm 30V 0.3V   |
| 7. |  |

**PIN OUT**

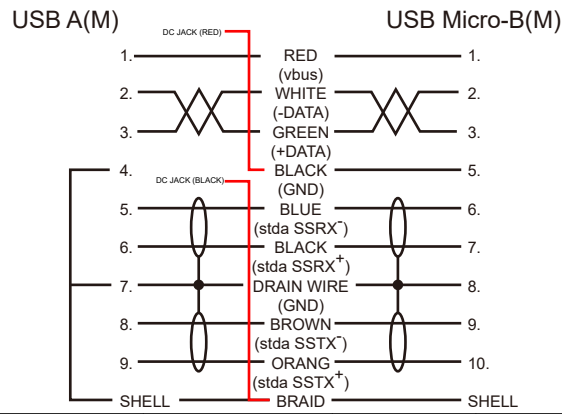

| Jargy part no.                | Client part no. | Approved | SCALE | UNIT |
|-------------------------------|-----------------|----------|-------|------|
| CBL-D302MBHMWBPW-xlLA         |                 |          |       | mm   |
| Drawing Name                  |                 | Drawn    | Date  | REV. |
| USB 3.0 A to MicroB Cable M/M |                 |          |       | 1.0  |

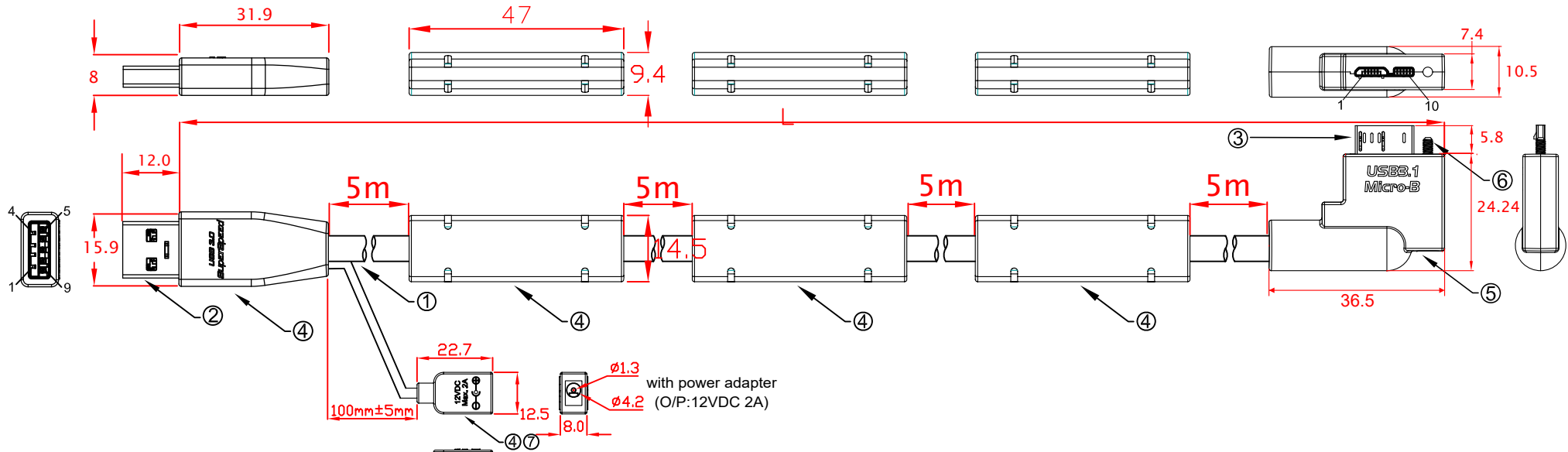

Operating Temperature: 0°C~70°C  
 Operating Humidity: 20%~80% (no condensation)  
 Storage Temperature: -25°C~85°C  
 Storage Humidity: 20%~80% (no condensation)

L:  
 CBL-D302MBSNWPW-20mLA 20000mm±50mm

| No | MATERIALS LIST:  |
|----|--|
| 1. | CABLE:UL2725 (28AWG*1PR+D+AM)x2C+28AWG*1PR+24AWG*1C+AM+B OD:5.6mm PVC JACKET COLOR:BLACK |
| 2. | CONNECTOR:USB 3.0 A/M, 9P, BLUE INSULATOR SOLDER TYPE, NICKEL PLATED SHELL               |
| 3. | CONNECTOR:USB 3.0 MicroB/M, 10P, BLACK INSULATOR SOLDER TYPE, NICKEL PLATED SHELL        |
| 4. | PVC MOLDED HOUSING, BLACK COLOR  |
| 5. | ABS HOUSING, BLACK COLOR   |
| 6. | SCREW:#4x23.32 M2  |
| 7. | DC JACK 1.3mm 30V 0.3V   |

**PIN OUT**

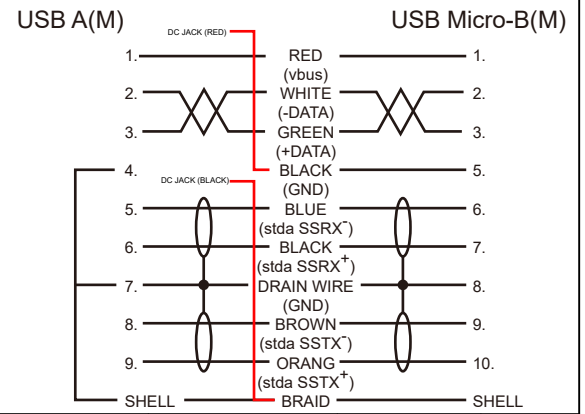

| Jargy part no.                | Client part no. | Approved | SCALE | UNIT |
|-------------------------------|-----------------|----------|-------|------|
| CBL-D302MBSNWPW-xmlA          |                 |          |       | mm   |
| Drawing Name                  |                 | Drawn    | Date  | REV. |
| USB 3.0 A to MicroB Cable M/M |                 |          |       | 1.0  |

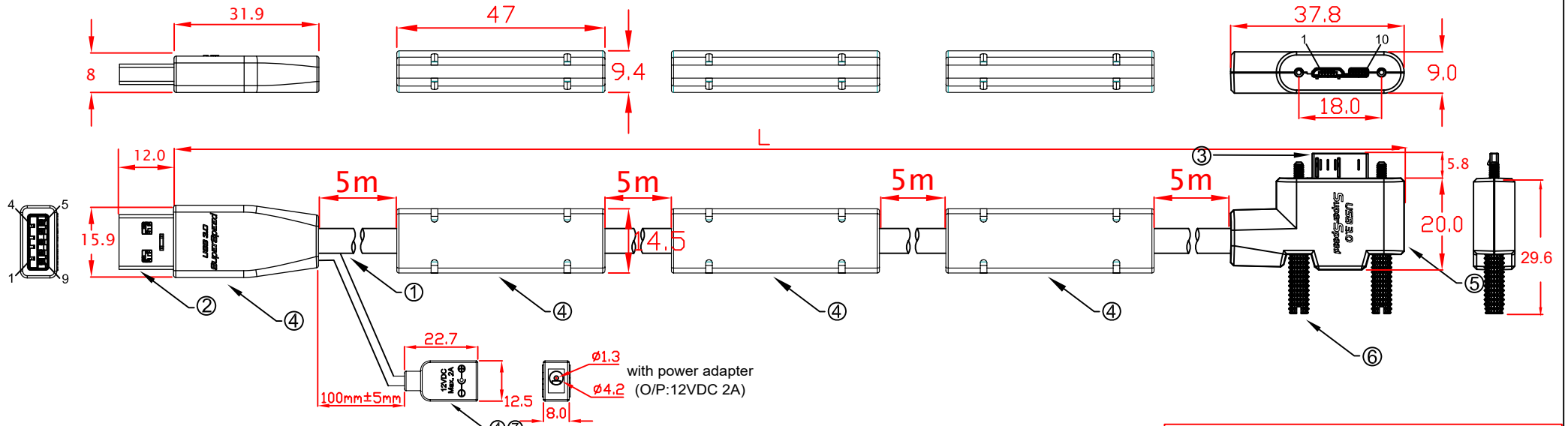

Operating Temperature: 0°C~70°C  
 Operating Humidity: 20%~80% (no condensation)  
 Storage Temperature: -25°C~85°C  
 Storage Humidity: 20%~80% (no condensation)

L:  
 CBL-D302MBSWPW-20mLA 20000mm±50mm

| No | MATERIALS LIST:  |
|----|--|
| 1. | CABLE:UL2725 (28AWG*1PR+D+AM)x2C+28AWG*1PR+24AWG*1C+AM+B OD:5.6mm PVC JACKET COLOR:BLACK |
| 2. | CONNECTOR:USB 3.0 A/M, 9P, BLUE INSULATOR SOLDER TYPE, NICKEL PLATED SHELL               |
| 3. | CONNECTOR:USB 3.0 MicroB/M, 10P, BLACK INSULATOR SOLDER TYPE, NICKEL PLATED SHELL        |
| 4. | PVC MOLDED HOUSING, BLACK COLOR  |
| 5. | ABS HOUSING, BLACK COLOR   |
| 6. | SCREW:#4x33 M2   |
| 7. | DC JACK 1.3mm 30V 0.3V   |

**PIN OUT**

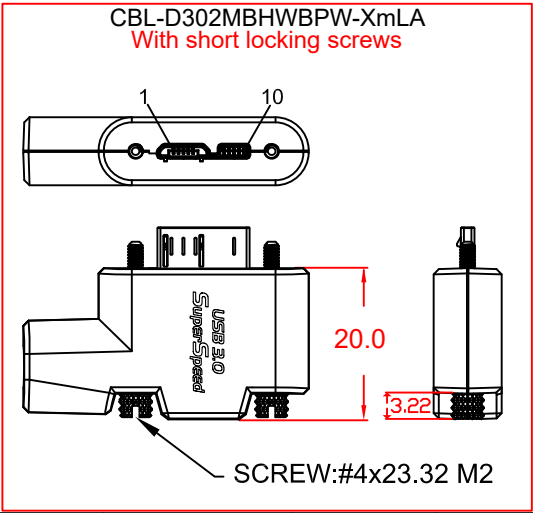
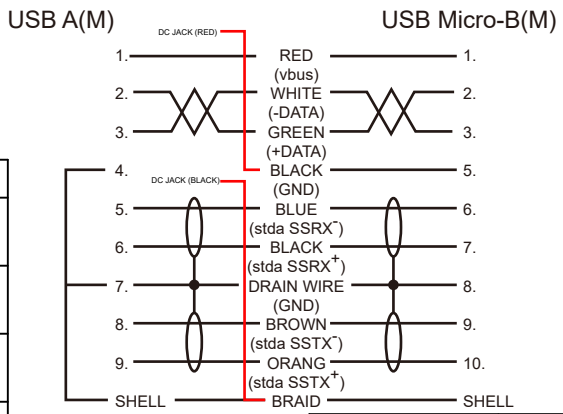

| Jargy part no.                | Client part no. | Approved | SCALE | UNIT |
|-------------------------------|-----------------|----------|-------|------|
| CBL-D302MBSWPW-20mLA          |                 |          |       | mm   |
| Drawing Name                  |                 | Drawn    | Date  | REV. |
| USB 3.0 A to MicroB Cable M/M |                 |          |       | 1.0  |

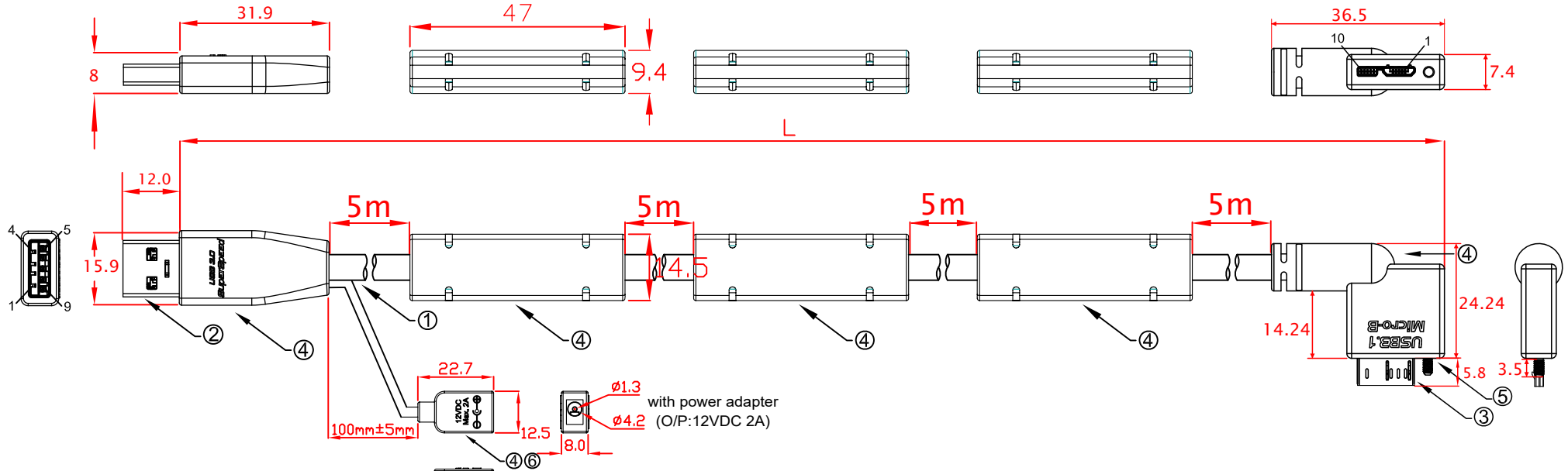

Operating Temperature: 0°C~70°C  
 Operating Humidity: 20%~80% (no condensation)  
 Storage Temperature: -25°C~85°C  
 Storage Humidity: 20%~80% (no condensation)

L:  
 CBL-D302MBHMWBPW-20mRA 20000mm±50mm

**PIN OUT**

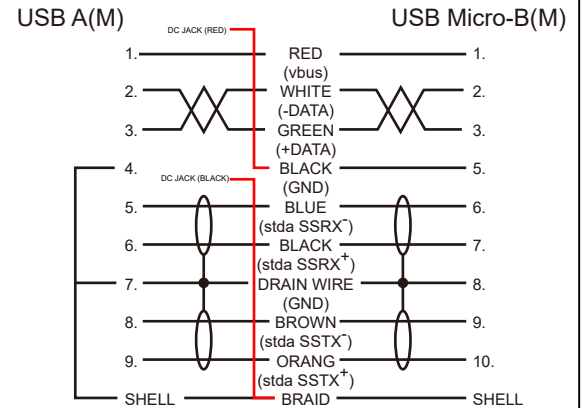

| No | MATERIALS LIST:  |
|----|--|
| 1. | CABLE:UL2725 (28AWG*1PR+D+AM)x2C+28AWG*1PR+24AWG*1C+AM+B OD:5.6mm PVC JACKET COLOR:BLACK |
| 2. | CONNECTOR:USB 3.0 A/M, 9P, BLUE INSULATOR SOLDER TYPE, NICKEL PLATED SHELL               |
| 3. | CONNECTOR:USB 3.0 MicroB/M, 10P, BLACK INSULATOR SOLDER TYPE, NICKEL PLATED SHELL        |
| 4. | PVC MOLDED HOUSING, BLACK COLOR  |
| 5. | SCREW:#4x23.32 M2  |
| 6. | DC JACK 1.3mm 30V 0.3V   |
| 7. |  |

| Jargy part no.                | Client part no. | Approved | SCALE | UNIT |
|-------------------------------|-----------------|----------|-------|------|
| CBL-D302MBHMWBPW-xmRA         |                 |          |       | mm   |
| Drawing Name                  |                 | Drawn    | Date  | REV. |
| USB 3.0 A to MicroB Cable M/M |                 |          |       | 1.0  |



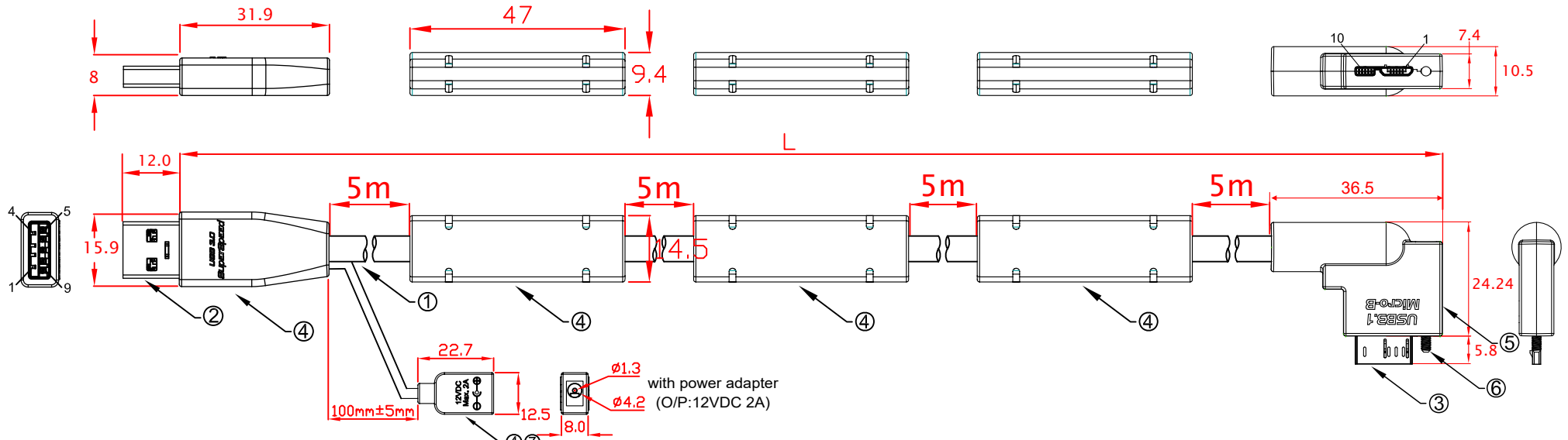

Operating Temperature: 0°C~70°C  
 Operating Humidity: 20%~80% (no condensation)  
 Storage Temperature: -25°C~85°C  
 Storage Humidity: 20%~80% (no condensation)

L:  
 CBL-D302MBSNWPW-20mRA 20000mm±50mm

PIN OUT

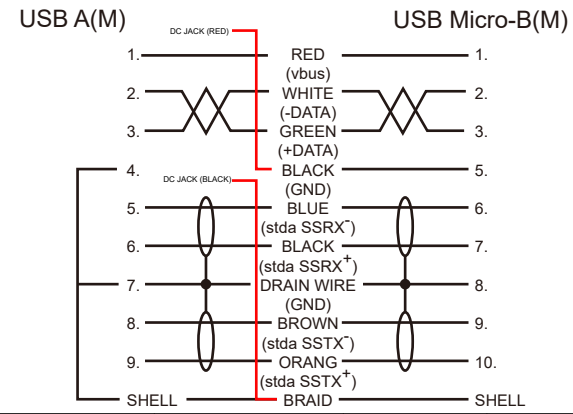

| No | MATERIALS LIST:  |
|----|--|
| 1. | CABLE:UL2725 (28AWG*1PR+D+AM)x2C+28AWG*1PR+24AWG*1C+AM+B OD:5.6mm PVC JACKET COLOR:BLACK |
| 2. | CONNECTOR:USB 3.0 A/M, 9P, BLUE INSULATOR SOLDER TYPE, NICKEL PLATED SHELL               |
| 3. | CONNECTOR:USB 3.0 MicroB/M, 10P, BLACK INSULATOR SOLDER TYPE, NICKEL PLATED SHELL        |
| 4. | PVC MOLDED HOUSING, BLACK COLOR  |
| 5. | ABS HOUSING, BLACK COLOR   |
| 6. | SCREW:#4x23.32 M2  |
| 7. | DC JACK 1.3mm 30V 0.3V   |

| Jargy part no.                | Client part no. | Approved | SCALE | UNIT |
|-------------------------------|-----------------|----------|-------|------|
| CBL-D302MBSNWPW-20mRA         |                 |          |       | mm   |
| Drawing Name                  |                 | Drawn    | Date  | REV. |
| USB 3.0 A to MicroB Cable M/M |                 |          |       | 1.0  |

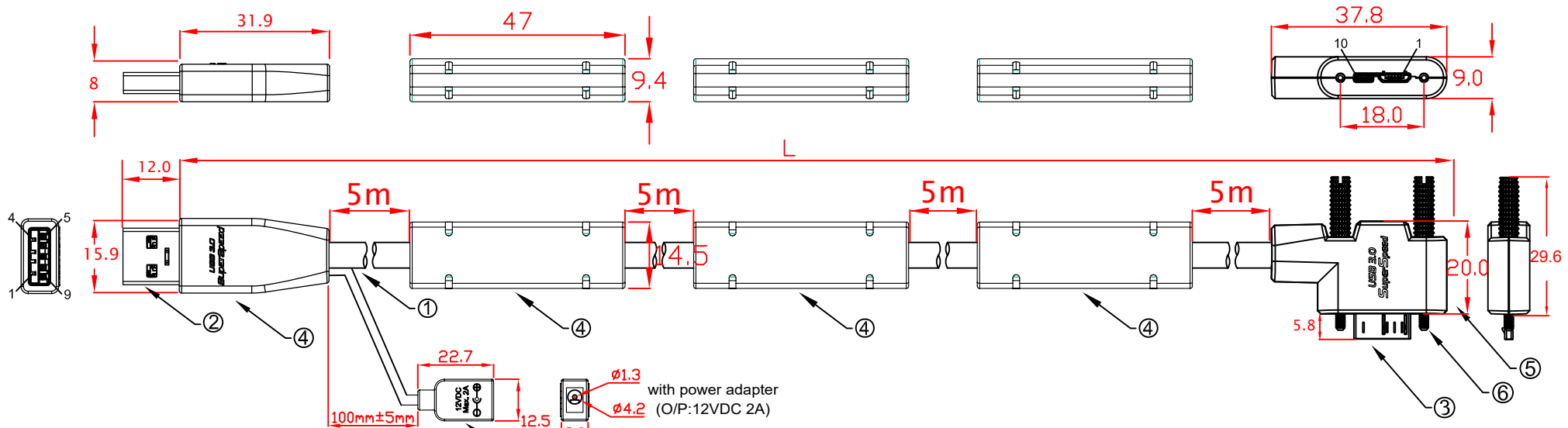

Operating Temperature: 0°C~70°C  
 Operating Humidity: 20%~80% (no condensation)  
 Storage Temperature: -25°C~85°C  
 Storage Humidity: 20%~80% (no condensation)

L:  
 CBL-D302MBSWPW-20mRA 20000mm±50mm

**PIN OUT**

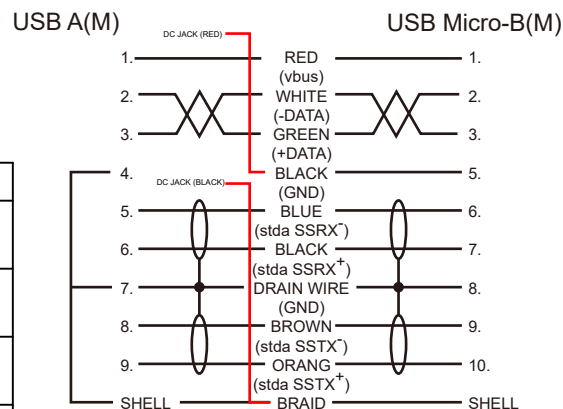

**CBL-D302MBHWBPW-XmRA**  
 With short locking screws

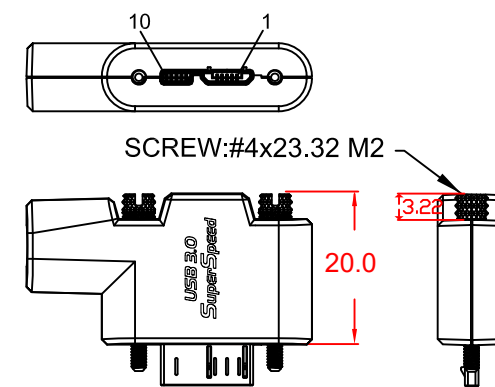

| No | MATERIALS LIST:  |
|----|--|
| 1. | CABLE:UL2725 (28AWG*1PR+D+AM)x2C+28AWG*1PR+24AWG*1C+AM+B OD:5.6mm PVC JACKET COLOR:BLACK |
| 2. | CONNECTOR:USB 3.0 A/M, 9P, BLUE INSULATOR SOLDER TYPE, NICKEL PLATED SHELL               |
| 3. | CONNECTOR:USB 3.0 MicroB/M, 10P, BLACK INSULATOR SOLDER TYPE, NICKEL PLATED SHELL        |
| 4. | PVC MOLDED HOUSING, BLACK COLOR  |
| 5. | ABS HOUSING, BLACK COLOR   |
| 6. | SCREW:#4x33 M2   |
| 7. | DC JACK 1.3mm 30V 0.3V   |

| Jargy part no.                | Client part no. | Approved | SCALE | UNIT |
|-------------------------------|-----------------|----------|-------|------|
| CBL-D302MBSWPW-20mRA          |                 |          |       | mm   |
| Drawing Name                  |                 | Drawn    | Date  | REV. |
| USB 3.0 A to MicroB Cable M/M |                 |          |       | 1.0  |

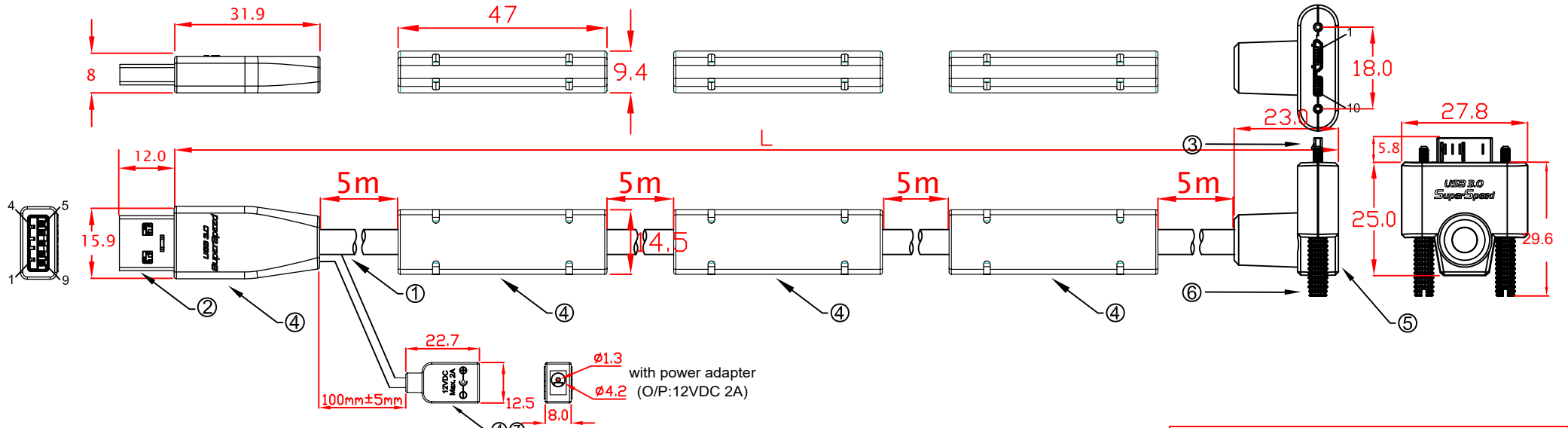

Operating Temperature: 0°C~70°C  
 Operating Humidity: 20%~80% (no condensation)  
 Storage Temperature: -25°C~85°C  
 Storage Humidity: 20%~80% (no condensation)

L:  
 CBL-D302MBSWPW-20mUA 20000mm±50mm

| No | MATERIALS LIST:  |
|----|--|
| 1. | CABLE:UL2725 (28AWG*1PR+D+AM)x2C+28AWG*1PR+24AWG*1C+AM+B OD:5.6mm PVC JACKET COLOR:BLACK |
| 2. | CONNECTOR:USB 3.0 A/M, 9P, BLUE INSULATOR SOLDER TYPE, NICKEL PLATED SHELL               |
| 3. | CONNECTOR:USB 3.0 MicroB/M, 10P, BLACK INSULATOR SOLDER TYPE, NICKEL PLATED SHELL        |
| 4. | PVC MOLDED HOUSING, BLACK COLOR  |
| 5. | ABS HOUSING, BLACK COLOR   |
| 6. | SCREW:#4x33 M2   |
| 7. | DC JACK 1.3mm 30V 0.3V   |

**PIN OUT**

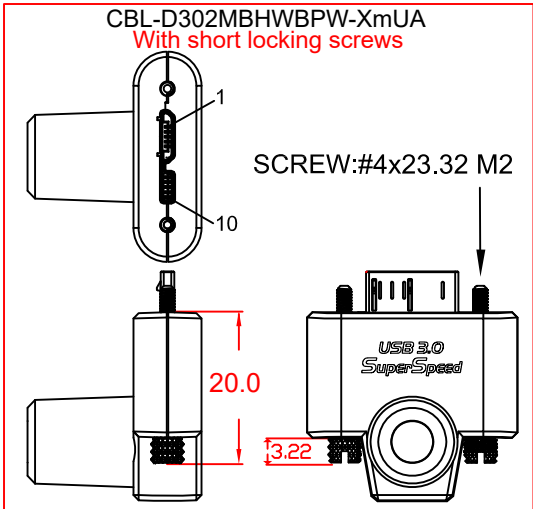
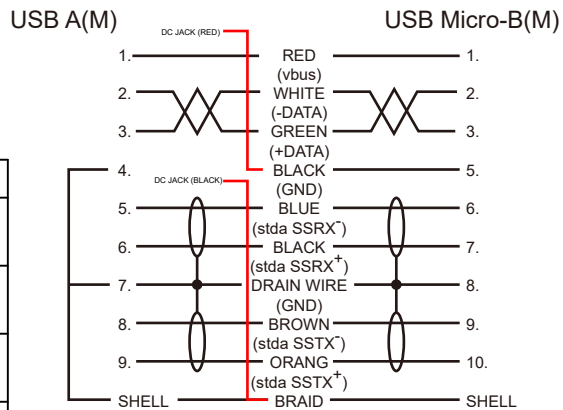

| Jargy part no.                | Client part no. | Approved | SCALE | UNIT |
|-------------------------------|-----------------|----------|-------|------|
| CBL-D302MBSWPW-20mUA          |                 |          |       | mm   |
| Drawing Name                  |                 | Drawn    | Date  | REV. |
| USB 3.0 A to MicroB Cable M/M |                 |          |       | 1.0  |

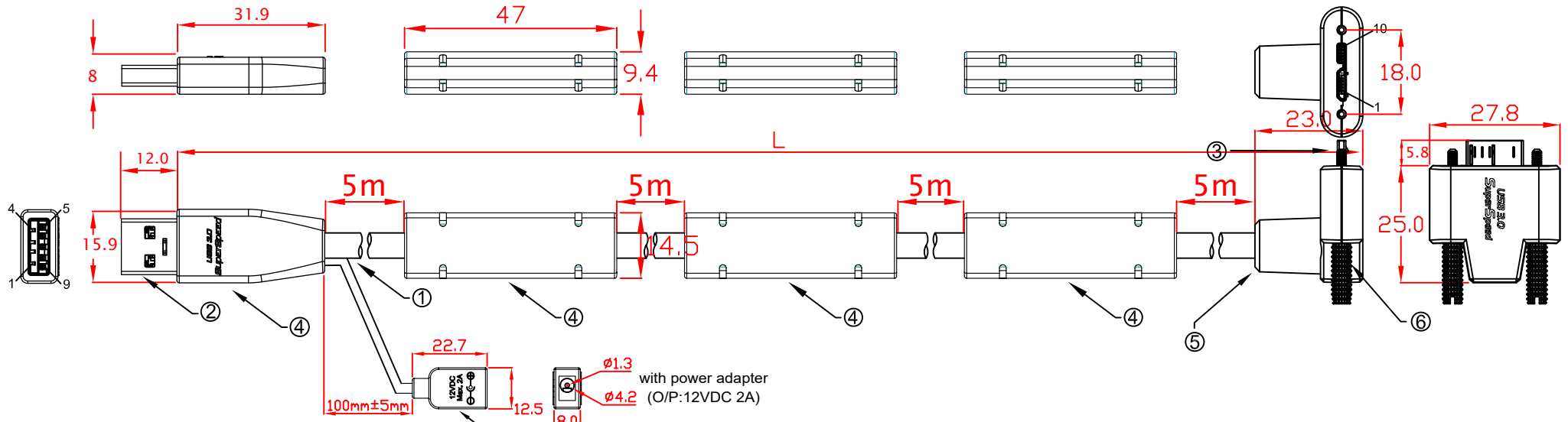

Operating Temperature: 0°C~70°C  
 Operating Humidity: 20%~80% (no condensation)  
 Storage Temperature: -25°C~85°C  
 Storage Humidity: 20%~80% (no condensation)

L:  
 CBL-D302MBSWBPW-20mDA 20000mm±50mm

| No | MATERIALS LIST:  |
|----|--|
| 1. | CABLE:UL2725 (28AWG*1PR+D+AM)x2C+28AWG*1PR+24AWG*1C+AM+B OD:5.6mm PVC JACKET COLOR:BLACK |
| 2. | CONNECTOR:USB 3.0 A/M, 9P, BLUE INSULATOR SOLDER TYPE, NICKEL PLATED SHELL               |
| 3. | CONNECTOR:USB 3.0 MicroB/M, 10P, BLACK INSULATOR SOLDER TYPE, NICKEL PLATED SHELL        |
| 4. | PVC MOLDED HOUSING, BLACK COLOR  |
| 5. | ABS HOUSING, BLACK COLOR   |
| 6. | SCREW:#4x33 M2   |
| 7. | DC JACK 1.3mm 30V 0.3V   |

**PIN OUT**

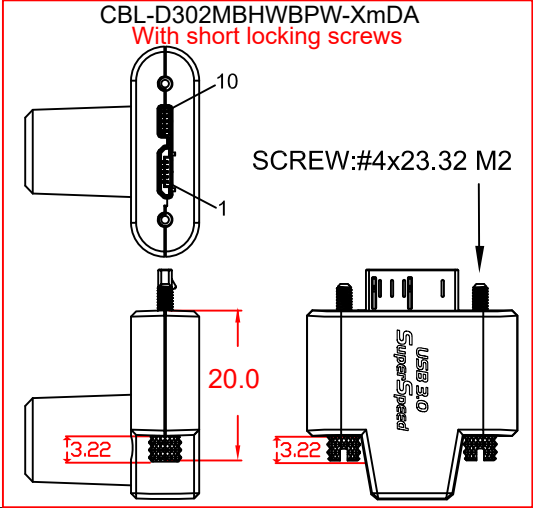
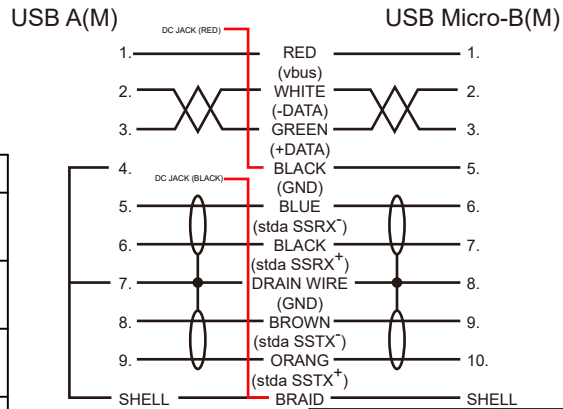

| Jargy part no.                | Client part no. | Approved | SCALE | UNIT |
|-------------------------------|-----------------|----------|-------|------|
| CBL-D302MBSWBPW-20mDA         |                 |          |       | mm   |
| Drawing Name                  |                 | Drawn    | Date  | REV. |
| USB 3.0 A to MicroB Cable M/M |                 |          |       | 1.0  |